

Skymap IIIC™ & Tracker IIIC™

Honeywell



Pilot Guide & Operating Manual

Skymap III C™ & Tracker III C™

Pilot Guide & Operating Manual

Manual Revision: SM2105-09 SIIC Pilot Guide.doc

Unit Software Version 1.22 + (System Model Packages SM4000 & TR4000)

Aeronautical Database: - Supplied courtesy of Jeppesen®

Cartographic Database - AND Products B.V.

Topographic – NOAA (National Oceanographic Atmospheric Administration)

CONTACT ADDRESS

Skyforce Avionics Limited
5 the Old Granary
Boxgrove, Chichester
West Sussex
PO18 0ES
Tel: +44 (0) 1243 783763
Fax: +44 (0) 1243 783992
Email: sales@skyforce.co.uk

Honeywell International Inc.
One Technology Center
23500 West 105th Street
Olathe, Kansas
USA 66061-1950 USA
Tel: 001 913 712 2613
Fax: 001 913 712 1302
Email: bendixking@honeywell.com

ELECTRONIC DOCUMENT DETAILS		
NETWORK PATH AND FILE NAME	FILE TYPE/VERSION	PRINTER
\\Kent\released_dwgs\SM4000\Master Manuals	Microsoft® Word	Network

HARD DOCUMENT DETAILS				
REVISION	DOI No.	ORIGINATOR	DESCRIPTION of CHANGE	DATE
9	DOI 159	D Allen	Add description of software versions and release document into DOI system	19/07/06

DOCUMENT APPROVAL

Authorised for Release for and on Behalf of Skyforce Avionics Limited:



Steve White – Hardware Design Specialist

NOTICES

PROPRIETARY NOTICE

The information disclosed within this document or separately supplied in furtherance of this document includes proprietary rights of Skyforce Avionics Ltd. and Honeywell International Inc. Neither this document nor the information disclosed herein or of a supplementary nature shall be reproduced or transferred to other documents or used or disclosed to others for manufacturing purposes, or for any other purposes, except as specifically authorised in writing by Skyforce Avionics Ltd. or Honeywell International Inc. Skyforce Avionics Ltd. is a subsidiary of Honeywell International Inc. Copyright © 2006 Honeywell International Inc. All rights reserved.

TRADEMARK NOTICE

“Skyforce” and the Skyforce logo are registered trademarks of Honeywell International Inc., U.S. and UK Patent & Trademark Office’s.

FLIGHT MANUAL

The information contained with this manual is for reference use only. If any information herein conflicts with similar information contained within the Aeroplane Flight Manual Supplement, the information in the Aeroplane Flight Manual Supplement shall take precedence.

Information in this document is subject to change without notice. Honeywell reserves the right to change or improve its products and to make changes in the content without notification.

TABLE OF CONTENTS

SECTION 1 BASIC OPERATION	1
INTRODUCTION	1
DEFINITIONS, ACRONYMS AND ABBREVIATIONS	3
<i>Definitions</i>	3
<i>Acronyms and Abbreviations.</i>	4
A QUICK LOOK AT YOUR UNIT	8
<i>KEY TO DRAWINGS</i>	8
<i>KEY TO DRAWING</i>	9
<i>Standard Accessories</i>	9
<i>Optional Accessories</i>	9
GENERAL INFORMATION	11
Soft Keying	11
Screen Orientation	11
Software Architecture	11
Memory Locations	14
Screen Icons	14
POWER AND ANTENNA CONSIDERATIONS	16
Power	16
Antenna Considerations (Skymap IIIC only)	18
SECTION 2 QUICK REFERENCE GUIDE	1
INTRODUCTION	1
INITIALISING YOUR UNIT	1
SOFTWARE STRUCTURE	2
Selecting Demo Mode	2
DATABASE SELECTION	3
A Quick Word On DIRECT TOs And Flight Plans	3
VISUAL DIRECT TO AND DATA INTERROGATION	4
DIRECT TO a Specific Latitude- And Longitude	4
Manual DIRECT TO And Data Interrogation	5
USER WAYPOINTS	5
Editing/Creating A User Waypoint Manually	5
Editing/Creating A User Waypoint Visually	5
Saving A User Waypoint In Flight	6
FLIGHT PLANS	7
Editing/Creating A Flight Plan Manually	7
Editing/Creating A Flight Plan Visually	7
Selecting A Flight Plan To Fly	8
Selecting A Map Mode Navigation Presentation	9
Viewing ETAs/Skip Waypoints	9
Ten Nearest Search	9

SETUP MAP FUNCTIONS	10
SETUP OF NAVIGATION FUNCTIONS	12
CLEAR MEMORY	13
SECTION 3 DETAILED OPERATION	1
TITLE AND HELP SCREENS	1
Self Test and Initialisation	2
Main Menu Screen	3
Note Pad Screen	3
GPS STATUS SCREENS (SKYMAP IIIC ONLY)	5
Adjusting Time and Date	7
Setting Local Time Offset	8
Setting Present Position	9
DATA INPUT	11
FLIGHT PLANNING SCREENS	13
User Waypoints	13
Viewing User Waypoints	15
Manual User Waypoint Editing	16
Graphical User Waypoint Editing	17
Editing User Airports	18
Flight Plans	18
Manual Flight Plan Building and Editing	19
Manually Inserting a Waypoint into a Flight Plan and Manual DIRECT TO	20
Graphical Viewing and Editing of Flight Plans	23
Airways Flight Planning	25
MAP MODE SCREENS	26
Data Interrogation and Graphical DIRECT TO	27
<i>Airport Information</i>	28
<i>Beacon Information</i>	29
<i>General Icon Information</i>	30
<i>Airspace Interrogation</i>	30
NAV MENU SCREENS	32
Selecting a Flight Plan	34
Ten Nearest	36
<i>Airports</i>	36
<i>Beacons</i>	37
MAP MODE WITH NAV INFORMATION	39
Viewing En-route ETA's and Direct-To Page	40
<i>Direct To</i>	41
Arrival at an En-route User Waypoint	42
Arrival at Your Final Destination	43
Alternative Navigation Map Modes	44
<i>TOPO ON / TOPO OFF Large Text Mode</i>	44
<i>TOPO ON / TOPO OFF CDI (Pseudo CDI) Mode:</i>	44
DEMO MODE	47
E6-B CALCULATOR	49

Density Altitude/TAS/Winds Aloft Calculator	49
Vertical Navigation (VNAV)	50
Trip/Fuel Planning	52
Sunset/Sunrise Calculator.	53
APPENDIX A SETUP SCREENS	1
SETUP SCREENS	1
Map Setup Screens	1
NAV Mode Setup	7
Personal Identification Number (PIN) Setup	9
<i>Auto Power-On Lock</i>	11
Installation and Diagnostic Screens	13
<i>Screen Position Setup</i>	13
<i>View Logs</i>	14
<i>Clear Memory</i>	15
<i>Data In/Out</i>	17
APPENDIX B WARNING SCREENS	1
<i>RAM Lost Warning</i>	1
<i>Memory Battery Warning</i>	1
<i>PIN Lock Warning</i>	2
<i>Lock Out Warning</i>	2
<i>New Data Card Warning</i>	3
APPENDIX C MEMORY CARDS	1
MEMORY CARDS	1
Data Areas	1
Changing the memory card	1
Minimum Safe Altitudes (MSA)	2
<i>Flight Plan building.</i>	2
<i>During Flight</i>	2
Worldwide ICAO Codes.	3
APPENDIX D HOW DOES GPS WORK?	1
INTRODUCTION TO GPS	1
What Is GPS?	1
How Does It Work?	1
Accuracy and Reliability	2
APPENDIX E DIFFERENTIAL FUNCTIONS (SKYMAP IIIC ONLY)	1
DIFFERENTIAL GPS	1
What Is DGPS?	1
How Does DGPS Work?	1
Uses Of DGPS	2
Data Connection	2
APPENDIX F SERIAL DATA OUTPUT SENTENCES	1
SERIAL DATA FORMATS	1
NMEA 0183 Data Format	1
NMEA – RMC Sentence	1
NMEA – GGA Sentence.	1

NMEA – RMB Sentence	1
Notes on the RMB sentence	2
RS-232C AR-NAV Data Format	3
Notes on the AR-NAV sentence.	3
APPENDIX G SERVICE AND WARRANTY	1
APPENDIX H PREVIOUS SOFTWARE RELEASES	1

THIS PAGE INTENTIONALLY BLANK

SECTION 1 BASIC OPERATION

INTRODUCTION

All of us at Honeywell congratulate you on choosing this product. You are now the owner of one of the most sophisticated yet simple-to-use navigational aids available today. We understand you probably can't wait to see it in action but before you try to use it do please take the time to read through this Manual and understand its many interesting and useful features. Time spent in familiarising yourself with your new Bendix/King unit will be more than repaid by trouble-free operation later, and more importantly safe and accurate navigation.

We have made the operation of this unit as intuitive as possible through the use of soft keying and on-screen help, thus reducing users' dependence on the Manual. You should very quickly find that handling it efficiently and expertly becomes second nature to you. Don't be afraid to experiment. No matter which Key you activate, your unit will not be damaged. If you do get into a mess, simply switch off and back on again to reset all functions. We must mention just one word of caution. **Never remove the memory card whilst the unit is switched on and never attempt to switch the unit on when there is no memory card fitted.**

Whichever model of our equipment you have chosen, we at Honeywell are sure you will be pleased with its performance. We thank you for your custom and wish you many happy and safe hours flying.

WARNING

The Global Positioning System (GPS) satellite constellation is operated by the Department of Defence (DoD) of the United States, which is solely responsible for its accuracy and maintenance. Although declared fully operational on July 17th 1995, the system is still under development and subject to changes, which could affect the accuracy and performance of all GPS equipment.

Use this equipment at your own risk. Your new Bendix/King equipment is a precision navigation aid but like any navigational aid it can be misused or misinterpreted and so become unsafe. You are strongly advised to read and fully understand this Manual before using it. Your unit has a DEMO MODE or simulation facility that allows you to practice with it before you begin using it for actual navigation.

Whenever you are using the unit for navigation in the air you should treat it as a **supplemental navigation system**. You should always carefully compare indications from your Bendix/King equipment with the information available from all other navigation sources including NDB's, VOR's, DME's, visual sightings, charts, etc. For safety, any discrepancies observed should be resolved immediately.

The altitude calculated by GPS equipment is geometric height above a theoretical mean sea level of a mathematically calculated ellipsoid that approximates to the shape of the earth. This altitude can differ significantly from that displayed by your pressure altimeter. You must therefore **NEVER USE GPS ALTITUDE FOR VERTICAL NAVIGATION OR TERRAIN CLEARANCE.**

The coloured terrain elevation feature is provided solely as an aid to visual identification of terrain features and must never be used for terrain clearance.

The European Obstacle Data has been generated from each of the countries AIP en-route

navigation obstacles section. The respective national authorities do not guarantee that the AIP details are correct or that the list of obstacles is complete.

This equipment is not a replacement for your chart. It is intended as an **aid to VFR navigation only**. The database within the equipment has been compiled from the latest official information available, and although every care has been taken in the compilation, the manufacturers will not be held responsible for any inaccuracy or omissions therein.

WARNING

Your Bendix/King product is of superior design and craftsmanship and should be treated with care. The suggestions below will help you enjoy the product for many years.

- Keep the Skymap and all its parts and accessories out of the reach of small children.
- Keep the Skymap dry. Precipitation, humidity and liquids containing minerals will corrode the electronic circuits.
- Do not use or store the Skymap in dusty, dirty areas as its components may be damaged.
- Do not store the Skymap in excessively hot areas. High temperatures can shorten the life of electronic devices, damage batteries and warp or melt plastics.
- Do not store the Skymap in excessively cold areas and try to avoid transferring the unit suddenly from a cold to a warm environment. When the unit warms up to its normal temperature, condensation can form inside, which may damage the electronic circuits. If you suspect that there may be internal condensation, allow the unit to warm up slowly and the condensation to clear of its own accord before applying power.
- Do not attempt to open the casing. Only trained and qualified Honeywell technicians can service and repair your unit. Other than the data card the Skymap contains no user-serviceable parts. Non-expert handling may damage the Skymap.
- Do not drop or knock the Skymap. Rough handling may damage the case or internal components.
- Do not use harsh chemicals, cleaning solvents or strong detergents to clean the Skymap. Wipe it with a clean, dry cloth.
- Do not dispose of the Skymap by fire.

DEFINITIONS, ACRONYMS AND ABBREVIATIONS

Definitions

alphabetic: any of the following characters (b/ is a space):
b/ABCDEFGHIJKLMNOPQRSTUVWXYZ

alphanumeric: any of the following characters (b/ is a space):
b/ABCDEFGHIJKLMNOPQRSTUVWXYZ0123456789

baud: bits per sec

barometric altitude: pressure altitude corrected for barometric altimeter setting

bearing to waypoint: bearing from the present position to the active waypoint measured clockwise relative to true or magnetic north (true is implied unless magnetic is specified)

cross track error: distance from the present position to the nearest point on the desired course, and the direction (right or left) from the desired course to the present position

cursor field: a character position or group of adjacent character positions on which a cursor can appear

data entry field: A data entry field is a data field where the ENTER, SET or SELECT button must be pressed before data entered in the field becomes effective. A data entry field can be a single or multiple character cursor field. During data entry, the active cursor field remains reverse video.

data field: a character position or group of adjacent character positions which display a single data item; a data field may be a single character cursor field, or may contain multiple characters.

data list: an ordered list of data elements which a given cursor field can accept

desired track: The angle, which the desired flight path makes with respect to true north at the point nearest the present position. Magnetic desired track uses the local magnetic variation.

destination: If the active waypoint is not in the active flight plan, the active waypoint is the destination. If the active waypoint is in the active flight plan, the final waypoint in the flight plan is the destination.

distance to waypoint: distance from the present position to the active waypoint

en route safe altitude: the highest minimum safe altitude which will be encountered for a given flight path (present position to destination, via flight plan if appropriate; or a flight path being analysed by trip planning)

ground speed: absolute value of the rate of change of position

headwind: difference between true airspeed and ground speed when true airspeed is

more than ground speed

knots: Nautical miles per hour

minimum safe altitude: Minimum safe altitude is the highest minimum off route altitude for any sector within a 10 N.M. square centred at a given position. A minimum off route altitude of 7000 feet or less clears all known obstructions and terrain in a sector by 1000 feet; a minimum off route altitude greater than 7000 feet clears all terrain by 2000 feet. A sector is an area bounded by a 1° latitude/longitude grid.

RAIM: Receiver Autonomous Integrity Monitoring - A technique whereby a GPS receiver determines the integrity of the GPS navigation signals by a consistency check among redundant pseudo range measurements.

scrolling region: a set of consecutive cursor fields which display a portion of a scroll list; "scroll up" means that the data item in each cursor field in the scrolling region moves to the preceding cursor field. The data item in the first cursor field disappears from the page, and the last cursor field displays the next item in the scroll list; "scroll down" is the opposite. If there is other data associated with the data in the cursor fields (such as waypoint numbers in flight plans), it also moves.

selected course: The angle, which the desired flight path makes with respect to true north at the active waypoint. Magnetic selected course uses the magnetic variation at the active waypoint; if the active waypoint is a VOR, the magnetic variation stored for that VOR is used.

special use airspace: any of the following: prohibited area, restricted area, warning area, alert area, MOA, Class CARSA, Class BTCA, unknown, danger, caution, training, CTA, or TMA type

standard rate turn: 3°/sec

tailwind: difference between ground speed and true airspeed when ground speed is more than true airspeed

terminal waypoints: waypoints that are duplicated within a country code or "unnamed" waypoints associated with an approach that are assigned to distinct airports

time to waypoint: distance to waypoint divided by ground speed

track: angle of the aircraft's path over the ground measured clockwise relative to true or magnetic north (true is implied unless magnetic is specified)

Acronyms and Abbreviations.

AC:	alternating current
ACT:	active (waypoint or flight plan)
ADF:	automatic direction finder
ANSI:	American National Standards Institute
APT:	airport

BASIC OPERATION

ARTCC:	air route traffic control centre
ASCII:	American standard code for information interchange
ATC:	air traffic control
ATF:	aerodrome traffic frequency
ATIS:	automatic terminal information service
A/C:	aircraft
baud:	or Baud Rate; a measurement of data transmission speed
BRG:	bearing
CAA:	Civil Aviation Authority
CAS:	calibrated airspeed
COM:	communication
CDI:	course deviation indicator
CTA:	control area
CTAF:	common traffic advisory frequency
CTR:	centre
CWI:	continuous wave interference
dB:	decibels
DC:	direct current
DIS:	distance
DME:	distance measuring equipment
DOD:	United States Department of Defence
DOT:	United States Department of Transportation
EFIS:	electronic flight instrument system
ELT:	emergency locator transmitter
ESA:	en route safe altitude
ETE:	estimated time en route
FAA:	Federal Aviation Administration
FAF:	final approach fix
FAR:	Federal Aviation Regulations
FPL:	flight plan
FPM:	feet per minute
FSS:	flight service station
ft:	feet
FT:	feet
G:	gravitational acceleration = $32.2 \text{ ft/sec}^2 = 9.8 \text{ m/sec}^2$
GAL:	gallons
GPS:	Global Positioning System
hr:	hour
HSI:	horizontal situation indicator
Hz:	hertz
IAF:	initial approach fix
IAP:	instrument approach procedure
IEEE:	Institute of Electrical and Electronics Engineers
IFR:	instrument flight rules
in.:	inches
INT:	intersection
kHz:	kilohertz
Kt.:	knots
KΩ:	kilohms
LAT:	latitude

LB:	pounds
LED:	light emitting diode
LON:	longitude
LONG:	longitude
LRU:	line replaceable unit
m:	meters
mA:	milliamperes
MATZ:	Military air traffic zone
MAHP:	missed approach holding point
MAP:	missed approach point
mB:	millibars
MF:	mandatory frequency
MHz:	megahertz
mi:	statute miles
min:	minutes
MOA:	military operation area
MSA:	minimum safe altitude
msec:	milliseconds
NDB:	non-directional beacon
N.M.:	nautical miles
NPA:	non-precision approach
NVM:	non-volatile memory
OBI:	Omni-directional bearing indicator
OBS:	Omni-directional bearing selector
PETE:	pointer ETE
RAD:	radial
RAM:	random access memory
REF:	reference
RMI:	radio magnetic indicator
RTCA:	Radio Technical Commission for Aeronautics
SA:	Selective Availability (intentional errors introduced by the DoD)
SAT:	static air temperature
sec:	seconds
SID:	Standard Instrument Departure
SNR:	signal to noise ratio
STAR:	Standard Terminal Arrival Route
SUP:	supplemental waypoint
TAS:	true airspeed
TAT:	total air temperature
TD:	time difference
TMA:	terminal control area
TSO:	technical standard order
UTC:	universal co-ordinated time (same as Greenwich Mean Time)
V:	volts
VHF:	very high frequency
VNAV:	vertical navigation
VOR:	very high frequency Omni-directional radio range
W:	Watts
wpt:	waypoint
μsec:	microsecond

BASIC OPERATION

μV:	microvolts
Ω:	ohms
°C:	degrees Celsius
°F:	degrees Fahrenheit

A QUICK LOOK AT YOUR UNIT

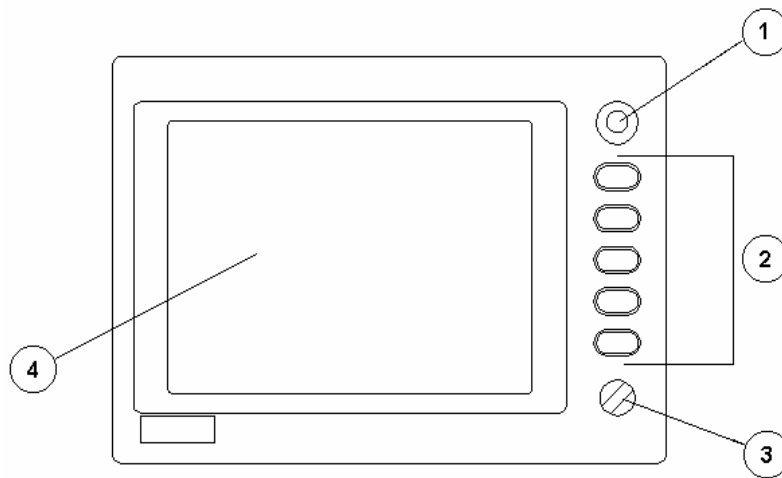

Skymap III C Front View

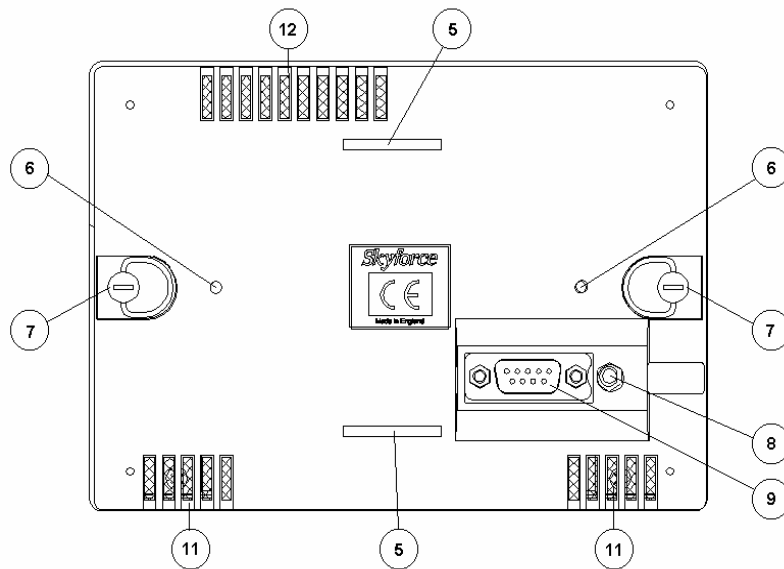

Skymap III C Rear View

KEY TO DRAWINGS

1. Joystick
2. Function Keys
3. ON / OFF / Brightness control
4. Full Colour TFT Liquid Crystal Display.
5. Leg Strap Slot.
6. Accessory Mounting Point.
7. Rear Cover Fasteners.
8. Antenna Socket (Skymap III C only)
9. Power/Data Connector.

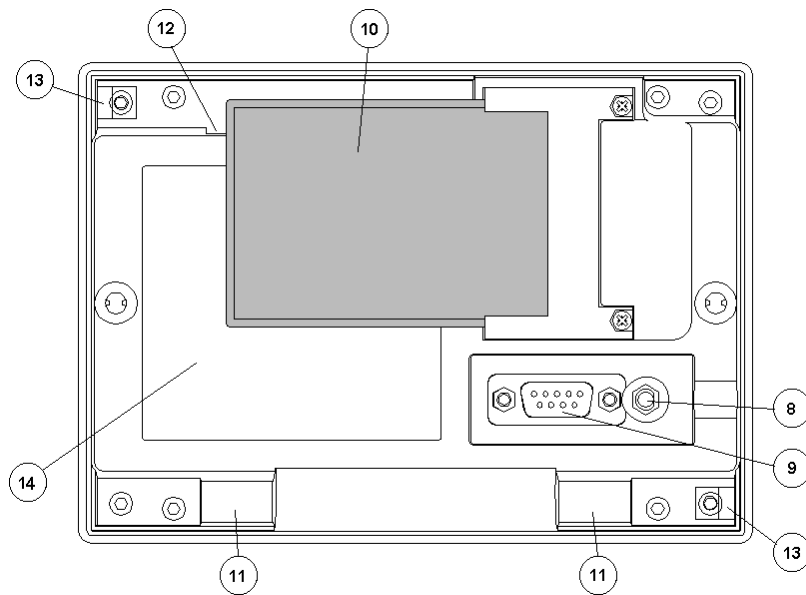

Skymap IIIC Rear View - Back Case Removed

KEY TO DRAWING

- 8. Antenna Socket (Skymap IIIC only)
- 9. Power/Data Connector.
- 10. Memory Card.
- 11. Cooling Air Intake (do not block).
- 12. Cooling Air Exhaust (do not block).
- 13. Rear Case Earth Tab (do not bend).
- 14. Serial number and modification level tag.

Standard Accessories

- SM2100 Portable Antenna with Cable and Suction Cup (Skymap IIIC only)
- SM2104 Carrying Case
- SM2200 Leg Strap
- SM2207 Cigar Adapter Cable (Skymap IIIC only)
- SM2102 Power/Data Cable (Tracker IIIC only)
- SM2105 Pilots Guide
- SM2106 Getting Started Card

Optional Accessories

- SM2201 Yoke Mount
- SM2204 Panel Mount
- SM2213 Panel Mount with Power/SMB Connector
- SM2202 Rack Mount
- SM2209 Gimbal Mount
- SM2228 Pedestal Mount
- SM2203 Avionics Interface Module (AIM)
- KA92 Low Profile External Antenna
- SM2212 SMB to BNC Adapter
- SM2101 Antenna Extension Lead
- SM2225/6/7 AC Power Adapter
- SMP514 PC Interface Cable
- FM25/26/2700 Flight Manager PC Software

THIS PAGE INTENTIONALLY BLANK

GENERAL INFORMATION

This section of the Manual explains how your Bendix/King unit should be used and provides you with an overview of the software architecture and screen presentation.

This manual provides a detailed explanation of each of the individual screens that your Bendix/King unit displays, and will take you step by step through each of them. To simplify this process each screen is numbered and indexed at the front of this Manual for reference. For those users who wish to get stuck into operating the system immediately, the Quick Reference Section of the Manual has been designed to get you up and running.

The operating system of the Bendix/King Skymap IIC and Tracker IIC has been developed from the highly successful Skymap II software. This operating system greatly reduces the number of key presses necessary to activate the various functions, especially those most frequently used in the air. The provision of a joystick makes it considerably simpler to operate the unit and allows you fast and efficient access to most functions.

Soft Keying

You will notice that a label is drawn alongside each valid key. Whenever a new function is selected, by pressing a valid key, a new screen is displayed along with its new key labels. This capability of drawing key labels that are only applicable to a particular screen is referred to as 'soft keying', and allows one key to perform multiple functions without the complications of multiple key presses on a conventional keypad.

For the purpose of describing the function of a particular key in this Manual, assume that all the keys on the pictured screen drawings are numbered 1 - 5 from top to bottom. The ensuing text will use this numbering sequence to refer to each specific key. The number shown alongside the pictured screen drawings refers to the number of the screen, which is called when that key is pressed. By using these numbers it is possible to follow the paths through the operating system for all functions. If the word RET is printed next to a key, this means that after the key function is performed the same screen is RETurned. A good example of this is ZOOM IN. All screen drawings show the full Skymap IIC version of software in Landscape Standard mode. Variations affecting Tracker IIC are described in the accompanying text.

Screen Orientation

The Skymap IIC and Tracker IIC software can be run in one of four display modes and so allows you to mount the unit either horizontally (either Landscape Standard or Inverse) or vertically (either Portrait Standard or Inverse). This enables the user to configure the unit for either left or right handed operation or place the keys along the left, right, top or bottom edges of the case. The default setting on first switch on is Landscape Standard, and it is this mode that is used to illustrate the functions of your unit in this Manual. Refer to Map Setup Screens in the Setup Screens section of this manual if you wish to alter your screen orientation.

Software Architecture

The software in your Bendix/King unit is tree structured, an analogy can therefore be drawn between the trunk of a tree and MAIN MENU. MAIN MENU is the heart of the operating structure and can be accessed by pressing the HELP key after power up or the MAIN MENU key at any other time.

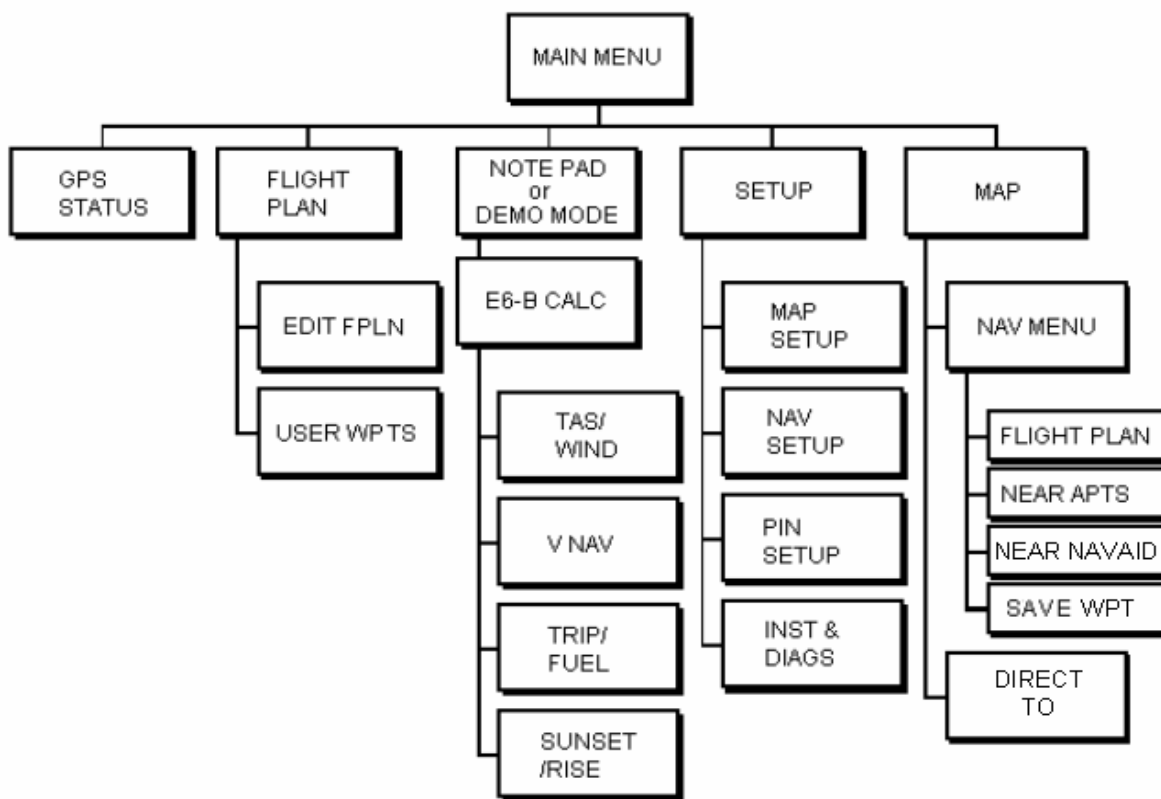

MAIN MENU has 5 main software branches, which in turn have their own sub software branches. The diagram above depicts the complete tree structure and will serve as a good point of reference whilst you are familiarising yourself with your unit.

GPS STATUS

Shows satellite signal strength, allows UTC, local offset, date and position to be set, which will speed up the initialisation of your unit.

FLIGHT

Allows user defined user waypoints and flight plans to be edited/created.

EDIT FPLN

Allows user defined flight plans to be edited /created either manually or visually.

USER WPTS

Allows user defined waypoints, airports and marker functions to be edited/created either manually or visually.

DEMO MODE

Allows you to practice operating the unit on the ground using a built-in simulator.

NOTE PAD

Allows up to 4000 characters of text, previously downloaded from a PC using Flight Manager™ software to be viewed. This Key is only available if **DEMO MODE** is not running. **DEMO MODE** can only be selected from the first screen after switching on the unit.

E6-B CALC

Allows the E6-B Calculator to be used.

TAS/WIND

Allows density altitude, TAS and winds aloft to be calculated.

V NAV

Allows vertical navigation to be Setup.

TRIP/FUEL

Allows fuel and trip information to be calculated.

**SUNSET/
RISE**

Allows sunset and sunrise times to be calculated.

SETUP

Allows Setup of map, navigation and input/output characteristics.

**MAP
SETUP**

Allows all map functions to be customised, including map orientation, airport names, map units, map datum, display orientation, language, minimum runway length/surface, extended track, auto zoom, zoom level map de-clutter facility, data logging rate and position reporting.

**NAV
SETUP**

Allows all the NAV functions to be customised, including CDI scale, CDI display, CDI alarm, arrival alarm, auto next leg/leg selection philosophy, turn anticipation, flight plan display and alarms.

PIN SETUP

Allows the PIN security function to be Setup.

**INST &
DIAGS**

Allows installation and diagnostics for data input/output and GPS receiver (Skymap IIIC only) to be performed. Flight logs can be viewed and various sections of memory can be cleared from here.

MAP

This is the primary operating mode of the unit.

NAV MENU

Accesses all navigation functions and MSA information. Joystick toggles NAV Mode.

**FLIGHT
PLAN**

Allows a flight plan to be selected and edited.

**NEAR
APTS**

Allows emergency search of 10 nearest airports, providing information and DIRECT TO capability. Includes Jeppesen and user defined airports which satisfies the minimum runway length and surface requirements.

NEAR NAVAID	Allows emergency search of 10 nearest beacons (VOR's and NDB's), providing information and DIRECT TO capability.
SAVE WPT	Allows your present co-ordinates to be saved in the next available user waypoint number.
DIRECT TO	Allows the user to perform a "goto" or DIRECT TO any point in the internal or user defined database. It may also be used to obtain information on any point in the database.

There are short cuts, which allow you to get to the primary operating mode, MAP mode, more easily; but in general if you wish to get to a specific function in another branch of software, work your way back up the present branch to MAIN MENU by pressing either the **SAVE & EXIT**, **PREV PAGE** or **MAIN MENU** key. Then select the branch of software that contains the desired function you wish to access.

Memory Locations

In the function descriptions, three types of memory, RAM, NVM and Memory Card, are mentioned. You may find it useful to know where various types of information are stored in order to make best use of the equipment. The RAM (Random Access Memory) is built into the unit and is used to store all user-defined data such as User waypoints and Flight plans. The RAM is maintained by battery power from an internal Lithium cell, which should be replaced by your Bendix/King dealer every three years to prevent loss of user-defined data. The NVM (Non Volatile Memory) is also built into the unit. It stores initialisation data, serial number, PIN number and performance log details. This memory is non-volatile which means it is retained even if the memory battery is removed. If you choose to activate the PIN number security feature (similar to that available on many car radios) the non-volatile nature of the NVM ensures your PIN cannot be tampered with or erased. The Memory Card is used to hold the operating system and the database. The memory card can be replaced periodically in order to upgrade the operating system and update the database.

Screen Icons

When showing any map screen - airports, beacons, towns, intersections, user waypoints and many other data classes are represented by symbols or icons, many of which are user selectable in the Map Setup Screens. Please refer to the Setup Screens Section of this Manual for further details.

SkymapIII C Screen Icon options

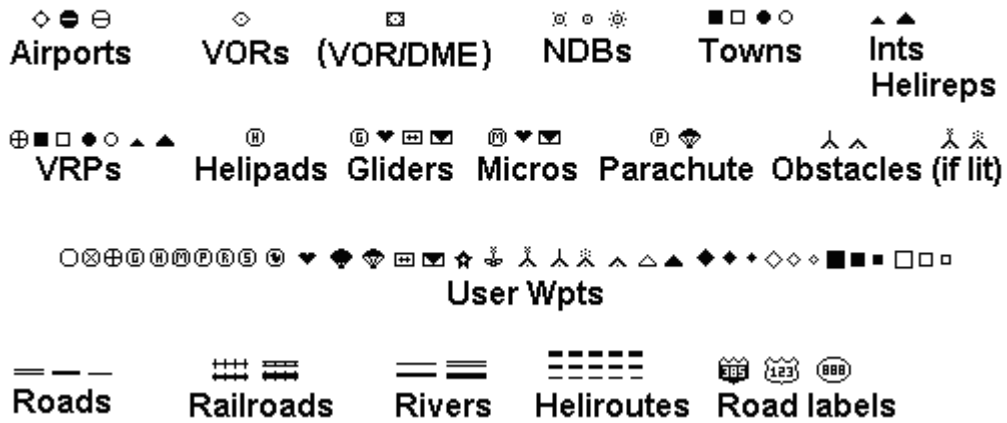

POWER AND ANTENNA CONSIDERATIONS

Power

Your unit is designed to operate from an external source providing a voltage between 10V to 33V DC. An optional AC Power (either 110V or 220/240V) Adapter is also available as an accessory for home use.

A pre-wired connector is supplied with your unit. The tail end of which either has a Cigar Adapter (Skymap IIIC) or flying leads (Tracker IIIC). The cable uses four coloured cores and a braided screen.

The red and blue cores of the cable should be connected to any DC supply between 10 and 33 Volts, capable of supplying 2 Amps.

1. Connect the RED core via a **3 Amp fuse** to the positive (+) side of a 10V-33V DC power source.
2. Connect the BLUE core and the braided screen to the negative (-) side of the same power source.

You may also power your unit from a 12 or 24 volt automobile type cigarette lighter socket. However certain of these lack proper circuit protection and may provide an unreliable supply so we recommend that wherever possible an approved aircraft power source be installed by a licensed radio engineer.

The yellow and green cores are the data in (yellow) and data out (green) lines. If your unit is a Tracker IIIC, the yellow core (data in) should be connected to the data output line of your GPS. Refer to the Data Input Section of this Manual for more details.

If your unit is a Skymap IIIC, the yellow core (data in) can also be connected to the data output line of another GPS, if required and the Skymap IIIC can be switched to Tracker mode and used as a repeater for that GPS.

Your unit also has a differential serial data input and external alarm outputs available on the 9 way connector for optional use. The green core of the cable is connected to the serial data output pin and may be used to drive an AirData computer, a plotter or a data recording device (see SECTION 3 APPENDIX F for details of data output).

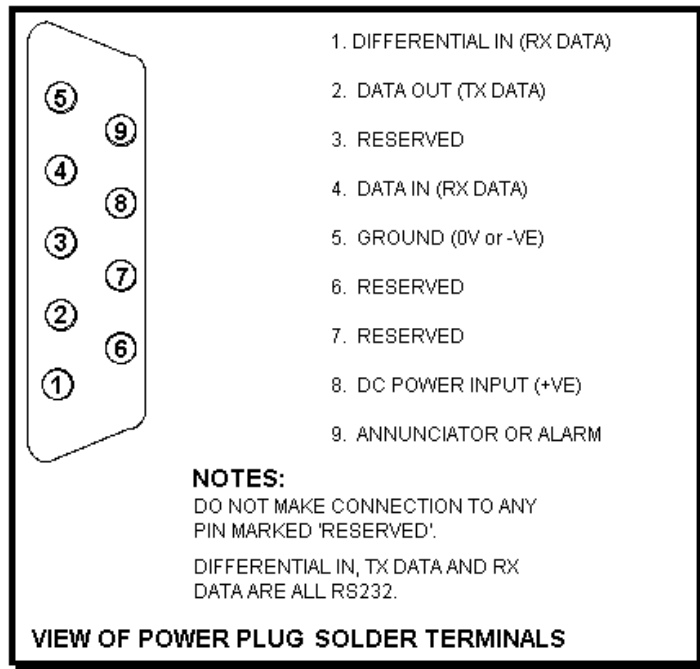

The data presented across the data output pins is controlled by the settings on Screen 35, Data Input/Output Setup and Test Screen. If you want to connect an external audio annunciator to your unit, do so in accordance with the following drawing and activate it's operation on Screen 23, NAV Mode Customisation Screen by setting EXTERNAL ALARM to ON.

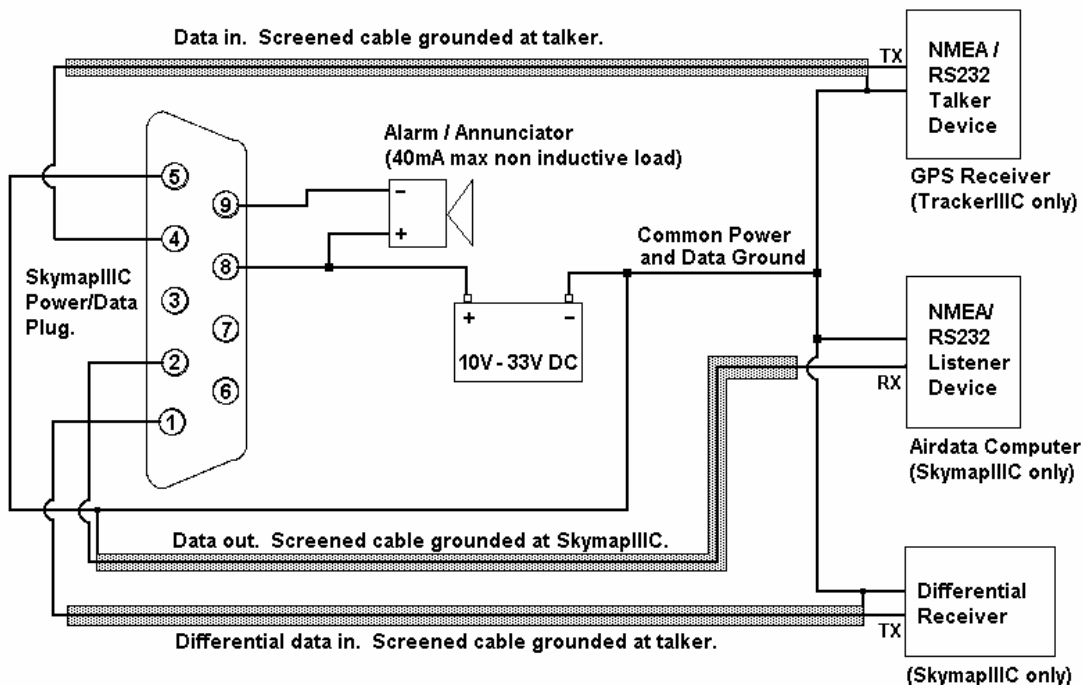

SkymapIIIIC / TrackerIIIIC Wiring Options

If you are not planning to connect either the green or yellow cores, please cut them back and insulate the cut end. Please do not make connection to pins 3, 6 or 7.

Antenna Considerations (Skymap IIIC only)

The Skymap IIIC is supplied with a portable antenna that is convenient for use in circumstances where the unit is removed from the aircraft regularly. Your Bendix/King dealer can advise you on other antenna options to suit different applications or improve performance.

When positioning the portable antenna, always ensure that the domed (the opposite side to that which carries the CE marking) face of the antenna is facing straight up to the sky and can “see” a large area of the sky, preferably right down to the horizon. In order to provide a 3-dimensional fix, Skymap IIIC needs to receive signals simultaneously from at least four satellites.

The radio signals from the GPS Navstar satellites are transmitted in an extremely high frequency band (1.5GHz). They can be regarded as having approximately the same penetration capabilities as light. This means that they are able to penetrate only transparent or very thin materials and will be blocked by almost any material that blocks light.

At least four and at times up to twelve GPS satellites should be in view from any place in the world at any time. These can, however, be absolutely anywhere in the sky and so, to ensure uninterrupted navigation it is essential that the antenna has direct line-of-sight contact with as much sky as possible.

If the position in which you wish to locate your Skymap IIIC is shielded from the sky and the standard antenna cable is not long enough for an acceptable installation bearing the above guidelines in mind, you may choose one of several options for remote antenna sitting. The simplest is to use the Bendix/King remote antenna extension cable. This allows the portable antenna to be extended by a further 6ft (2 metres) thereby allowing mounting up to 12ft (4 meters) away from the main unit. The antenna may be held in place there by using the rubber suction cup supplied (which should be slotted into the key hole in the antenna bracket) or fixed permanently in position by using the countersunk screw mounting holes in the antenna bracket. The rubber suction cup is ideal for temporary use in vehicles and light aircraft. The portable antenna is only splash proof and not fully waterproof. **Never mount this antenna permanently outside.**

For permanent external antenna mounting an external magnetic mount antenna is available for ground vehicles and an external low profile "tear drop" style antenna for aircraft. For more information about these accessories please contact your Bendix/King dealer.

THIS PAGE INTENTIONALLY BLANK

SECTION 2 QUICK REFERENCE GUIDE

This Section of the Manual is designed to provide you with a quick reference guide into the operation of your Bendix/King unit; taking you step by step through the most common functions. If more detail is required, please refer to the appropriate Sections in this Manual. The information contained within this Section is equally applicable to the Tracker IIC as it is to the Skymap IIC. Where the Tracker IIC operation differs, the differences are explained in italic text after each paragraph.

INTRODUCTION

Your Bendix/King unit is operated via a joystick, a series of 5 soft keys, and a rotary ON/OFF switch. The joystick allows movement of the pointer in MAP mode and is used for all forms of data entry or selection.

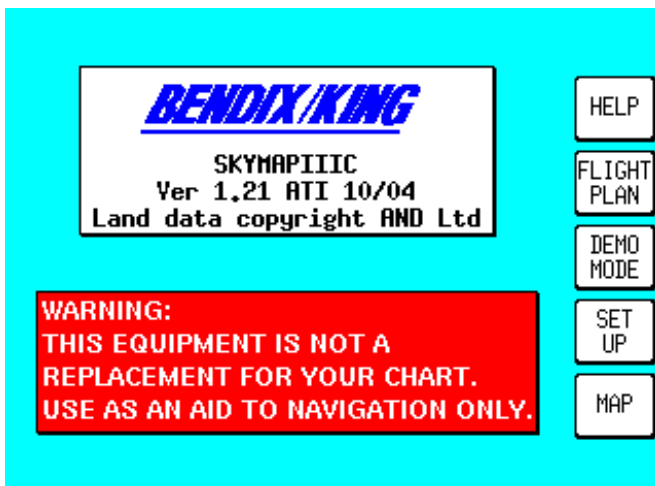

The appropriate key labels for a particular page are configured in software and drawn alongside the appropriate black key. The rotary ON/OFF switch is used for adjusting the brightness of your screen.

This screen is displayed, giving a warning regarding the expiry date of the Jeppesen® data. This must be acknowledged before you can continue. Please refer to APPENDIX G for details on obtaining data updates.

INITIALISING YOUR UNIT

When an antenna is attached and has a good all round view of the sky, the unit will achieve a position fix within 15 minutes. Ensuring that your GPS has rough UTC, date and position information can significantly speed up this process. To check this switch on the unit, select the **HELP** key followed by **GPS STATUS**.

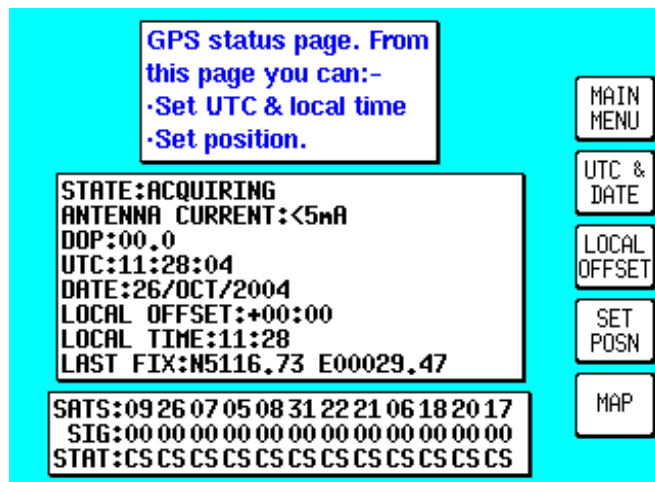

Altering UTC & DATE: Select **UTC & DATE**, followed by **ADJUST UTC**. Use the joystick to adjust the time, and then press **SET**. Now select **ADJUST DATE** and use the joystick to adjust the date, and then press **SET** followed by **GPS STATUS**. Option not available after the GPS has determined the correct time.

Altering Present Position: Select **SET POSN**, and use the joystick to adjust the latitude and longitude to your approximate position and then press **SET**. Alternatively select **SET POSN** and then **VIEW MAP**. Move the joystick

on the map to your approximate position (using the **ZOOM IN/ZOOM OUT** keys where applicable). Once there select **SET POSN** to change the position. Option not available

after the GPS has achieved a position fix.

When connected to an appropriate GPS output a "Tracker" unit will self initialise.

SOFTWARE STRUCTURE

Since the software is tree structured, an analogy can be drawn between the trunk of a tree and MAIN MENU. This can be accessed after powering on the unit by pressing the **HELP** key. MAIN MENU has 5 main software branches, which are as follows:

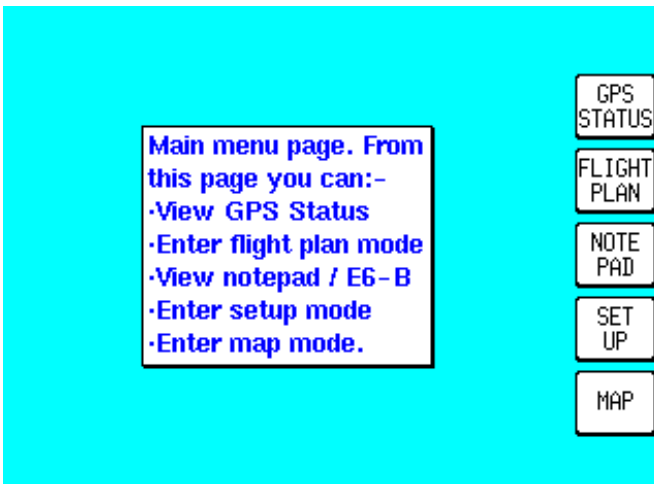

- **GPS STATUS:** Shows satellite signal strength, allows UTC, Local Offset, Date and Position to be set.
- **FLIGHT PLAN:** Allows user defined waypoints and flight plans to be edited/created.
- **NOTEPAD:** Allows access to NOTEPAD and E6-B functions, or turns off DEMO MODE. DEMO MODE can only be activated in the first power on screen.
- **SET UP:** Allows setup of map, NAV, PIN and input/output characteristics.
- **MAP:** This is the primary mode of the unit.

As a rule when trying to get to a specific function in another branch of software you should work your way back down the present branch to MAIN MENU by pressing either the **OK**, **PREV PAGE**, **SAVE & EXIT** or **MAIN MENU** key. Then select the branch of software that contains the desired function you wish to access. There are short cuts allowing you to get to the primary mode (MAP mode) more easily.

GPS STATUS is replaced with **DATA IN/OUT** in "Tracker" units. Tracker units will automatically be configured to accept data from external GPS/LORAN units.

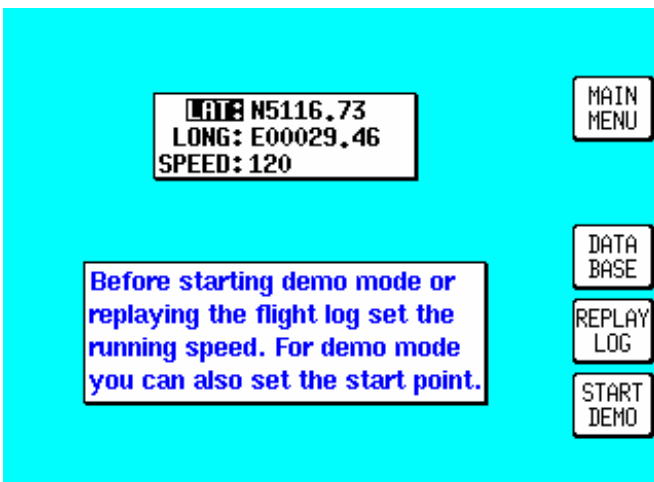

Selecting Demo Mode

Demo Mode allows you to become familiar with handling your unit on the ground by turning it into a simulator. Demo Mode can only be activated in the first title screen, available at power on.

Press **DEMO MODE** in the title screen, and use the joystick to select the start LAT and LONG and the ground SPEED you wish to use. Alternatively you can press the **DATABASE** key and select a data point from the database as a start point (for more information on achieving this please refer to Database Selection in this Section of the Manual). Once the

desired LAT/LONG and SPEED is entered press **START DEMO**.

DATABASE SELECTION

Both the internal (i.e.: Jeppesen and towns) waypoints and user-defined waypoints are stored in your unit in a series of databases.

During the normal use of your unit you will need to select items from these databases,

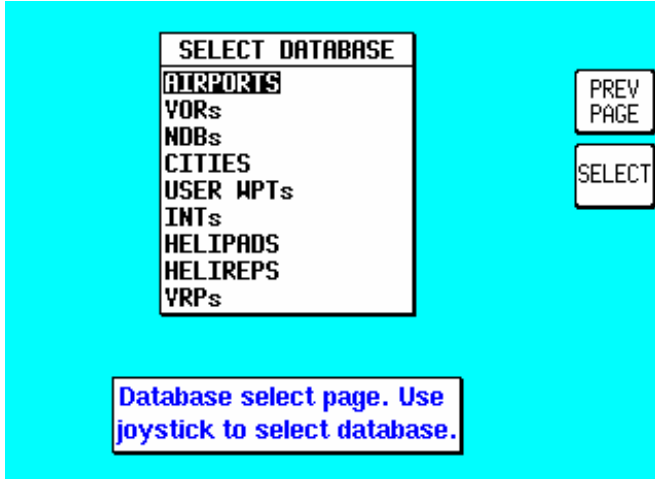

whether it is to find out airport frequency information, or select a DIRECT TO point or when creating a flight plan. In each case the adjacent screen will appear. Use the joystick to highlight the database in which the desired item is contained and press **SELECT**.

The second stage in the selection process requires you to choose the desired item. This is achieved by using the joystick. Once the desired item is displayed press **ENTER** to select the item. If the item required is in an aeronautical database (i.e.: AIRPORT, VOR etc) you may well have the ability to narrow the area of search by selecting a two letter identify in the AREA field. For a complete list of two letter ICAO identifiers please refer to APPENDIX C in this Manual. If the label in the AREA field says ALL then the search will include all countries available in your memory cards region.

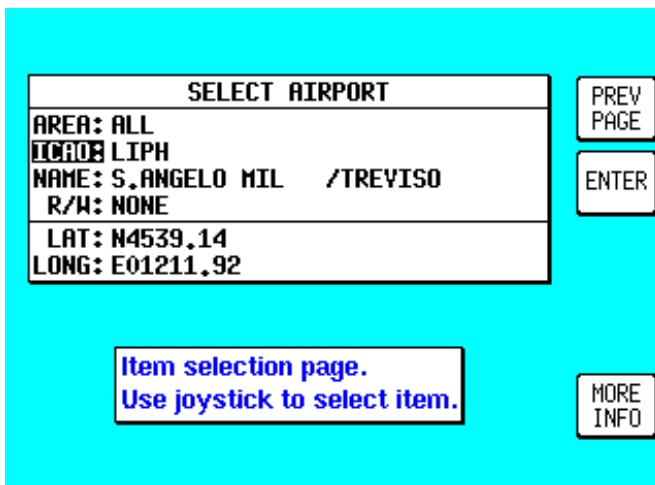

A Quick Word On DIRECT TOs And Flight Plans

A flight plan is a series of legs interspersed with waypoints, while a DIRECT TO is a one leg flight plan. A DIRECT TO can be performed at any time. If a DIRECT TO is performed when a flight plan is active, the flight plan will be put to sleep and the displayed navigation data in MAP mode will reference the DIRECT TO point. You will always know when a DIRECT TO is running because the DIRECT TO key will be labelled **DIRECT TO OFF**. Pressing this key will cancel the DIRECT TO. If a flight plan was previously running underneath it will automatically resume.

VISUAL DIRECT TO AND DATA INTERROGATION

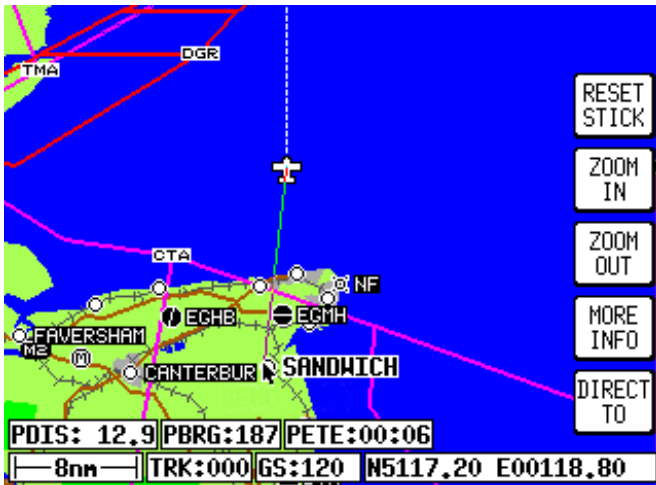

In MAP mode use the joystick to move the pointer to the desired location, or obtain the latitude/longitude and bearing/distance from present position.

If you have a ground speed your Bendix/King unit will calculate the time to reach the tip of the on screen pointer. This information is displayed in the PETE (or Pointer ETE) field. If you wish to invoke the DIRECT TO function press the **DIRECT TO** key.

The unit will then provide you with full navigation information to reach this point. Alternatively if you wish to obtain more

information on a specific data point, whether it is an airport, a section of controlled airspace or a beacon, move the pointer onto it and press the **MORE INFO** key.

Once the pointer has been activated by pushing the joystick it will remain active for 30 seconds; after which time it will automatically reset if not moved. Alternatively you can force a reset by pressing **RESET STICK**

DIRECT TO a Specific Latitude- And Longitude

To perform a DIRECT TO a specified latitude/longitude press the **DIRECT TO** key in MAP mode when the joystick is not active.

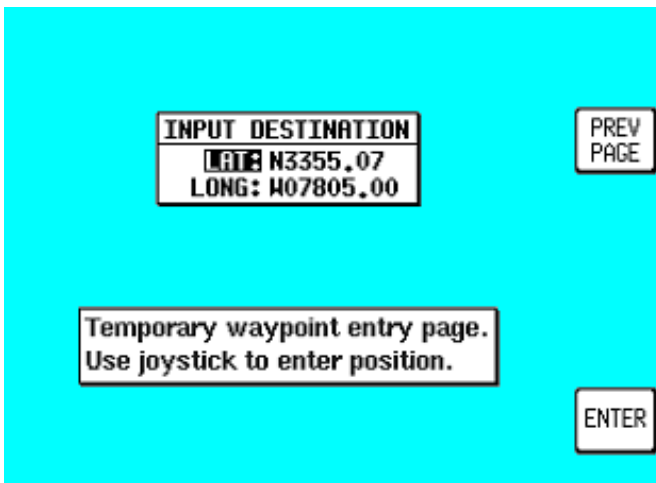

Then press TEMP WPT and use the joystick to dial in the required latitude and longitude, followed by ENTER. The unit will then provide you with full navigation information to reach this point.

Manual DIRECT TO And Data Interrogation

Provided the pointer is not active in MAP mode, press the **DIRECT TO** key. You will now be able to select the item from the database as explained in Database Selection in this section of the manual.

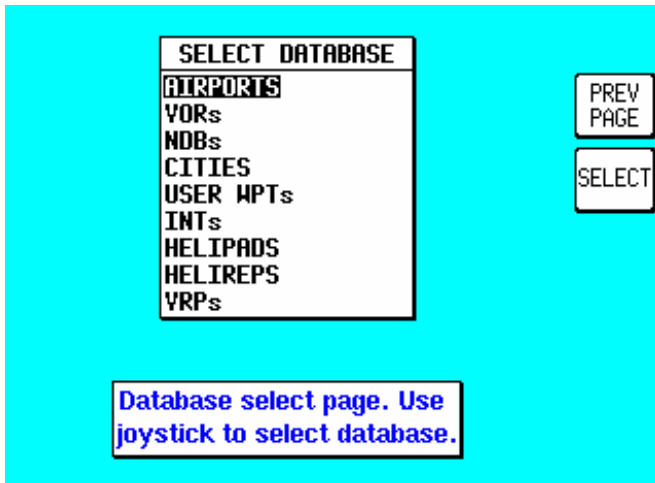

To activate the item as the **DIRECT TO**, press the **SELECT** key when the desired item is displayed. To get more information on the item press the **MORE INFO** key when the desired item is displayed.

If you are running a **DIRECT TO**, you can discontinue the navigation by pressing the **DIRECT TO OFF** key.

USER WAYPOINTS

Editing/Creating A User Waypoint Manually

From **MAIN MENU** select the **FLIGHT PLAN** key, followed by **USER WPTS**. Use the joystick to select the desired user waypoint number or name. Then press the **EDIT** key and use the joystick to edit the **NAME**, **LAT** and **LONG** fields.

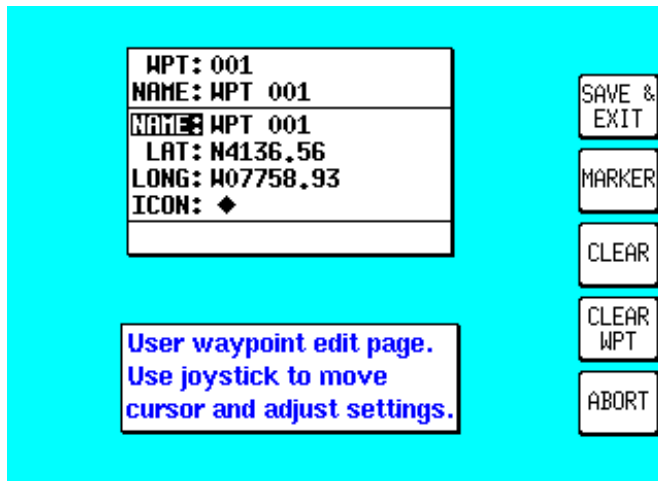

The entire user waypoint can be deleted by pressing **CLEAR WPT**. If you only wish to delete data in a particular field, as opposed to the entire user waypoint, move the cursor over the field label (i.e. **NAME**, **LAT**, **LONG**) and press the **CLEAR** key. To save a user waypoint press **SAVE & EXIT**. Use the **ABORT** key to return to **MAIN MENU** without saving. The **MARKER** key configures the user waypoint as a special type of waypoint with an associated alarm. Marker waypoints are discussed in detail in the Flight Planning section of this manual.

Editing/Creating A User Waypoint Visually

From **MAIN MENU** select the **FLIGHT PLAN** key, followed by **USER WPTS**. You may then use the joystick to select a specific user waypoint (either by number or name). Press the **VIEW MAP** key and the following screen will be shown with the previously selected user waypoint in the centre of the screen. If the previously selected user waypoint was empty your last position will be displayed.



A user waypoint can then be created as a distance and bearing from the displayed position or as a latitude/longitude. Press **ENTER WPT** to save the user waypoint to the first available memory location. An unwanted user waypoint can be removed by moving the pointer over it and pressing the **DELETE WPT** key.

If the user waypoint that you wish to delete is in a stored flight plan the message [PRESENT IN FLIGHT PLAN] will be displayed. A second press on the **DELETE WPT** key will however remove it, or you can move the joystick to cancel

the delete. Use the **PREV PAGE** key to save the changes and return to the User Waypoint screen.

Saving A User Waypoint In Flight

A user waypoint can be saved quickly in flight by pressing **NAV MENU** in MAP mode followed by **SAVE WPT**. You will immediately be returned to MAP mode with your current position saved to the next available user waypoint memory location.

FLIGHT PLANS

Editing/Creating A Flight Plan Manually

From **MAIN MENU** select the **FLIGHT PLAN** key followed by **EDIT FPLN**. Use the joystick to select the desired flight plan number and then press **SELECT**. To insert an item press **INSERT ITEM** and follow the Database Selection process explained earlier in this section of the manual.

To remove an item from the flight plan move the cursor over the item using the joystick and press **DELETE ITEM**. A flight plan can be systematically built using the **INSERT ITEM** key.

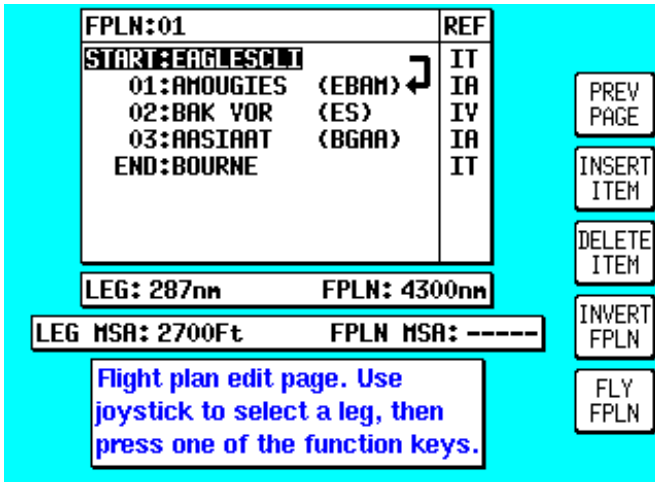

The flight plan can be inverted by pressing the **INVERT FPLN** key. If you wish to fly the flight plan, ensure that the flight plan arrow (shown on the side of the flight plan list) is highlighting the leg you wish to fly, then press **FLY FPLN**. Alternatively use the **SAVE & EXIT** key to return to the Flight Plan Cover Page, saving any changes made.

Editing/Creating A Flight Plan Visually

Visually

From **MAIN MENU** select the **FLIGHT PLAN** key, followed by **EDIT FPLN**. Use the joystick to select the desired flight plan number and then press **VIEW MAP**.



attach the turning point to a displayed waypoint. waypoint in the next available memory location.

If the selected flight plan was empty, the adjacent screen will appear showing your last position; if it was not, the start point of the flight plan will be shown in the centre of the screen. If the desired flight plan was empty you can use the joystick to move the pointer to the desired start waypoint and press **ADD WPT (ADD WayPoint)**.

This will place an S (for Start) next to the waypoint. Move the pointer to the next waypoint and press **ADD WPT** again. This will place an E (for End) next to the waypoint. In either case when the **ADD WPT** key is pressed the unit will try to. If one is not available it will create a user

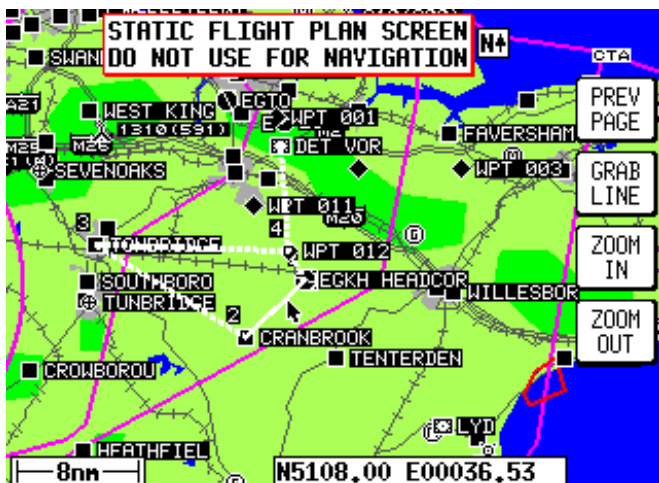

To systematically create additional legs, draw a line from the waypoint marked (E), with the pointer, to the next waypoint and press **ADD WPT** again. You will notice that the last point in the flight plan will always be labelled (E). Once you have finished building the flight plan press **PREV PAGE**, to detach the pointer from the flight plan. This key, if pressed again will return to the screen entered from, saving any changes made.

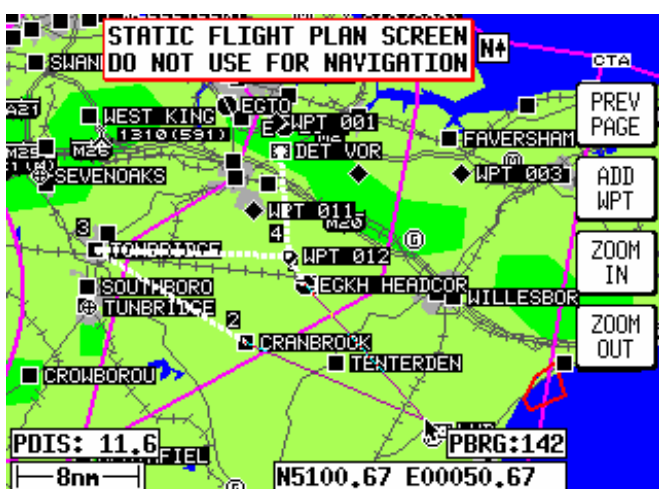

If you wish to add a new waypoint to a flight plan which you have stopped building, whether it is at the start, the end or the middle of the flight plan, you will need to highlight the appropriate point (i.e.: either the start waypoint (S), the end waypoint (E) or the leg line in which you wish to add a new waypoint). As soon as you do this, the **ADD WPT** or **GRAB LINE** key will appear. Press the **ADD WPT** or **GRAB LINE** key to join the pointer back to the flight plan line and then move it to the new waypoint (NOTE: Key 2 reverts to **ADD WPT**).

can be removed by pointing at them and pressing the **DELETE WPT** key. Use the **PREV PAGE** key to return to the screen entered from, saving any changes made.

Selecting A Flight Plan To Fly

From **MAIN MENU** select the **MAP** key, followed by **NAV MENU** and **FLIGHT PLAN**. Use the joystick to select the desired flight plan number and then press the **SELECT** key.

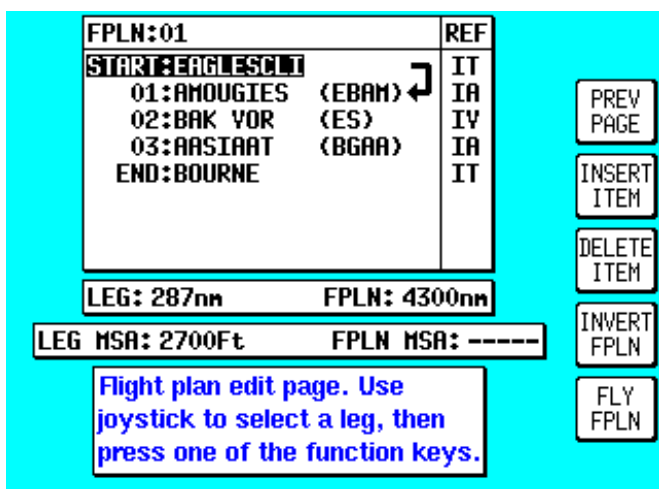

Ensure that the leg arrow is pointing at the initial leg that is to be flown and press **FLY FPLN**. The unit will immediately revert to map mode with the navigation information showing, using the pre-selected **MAP** mode presentation

Selecting A Map Mode Navigation Presentation

When in **MAP** mode and navigating to a waypoint, either with a **DIRECT TO** or as part of a flight plan, the unit is in Navigation MAP mode. The MAP presentation can be varied from Small Text (default) to Large Text to a CDI (Pseudo HSI) display.

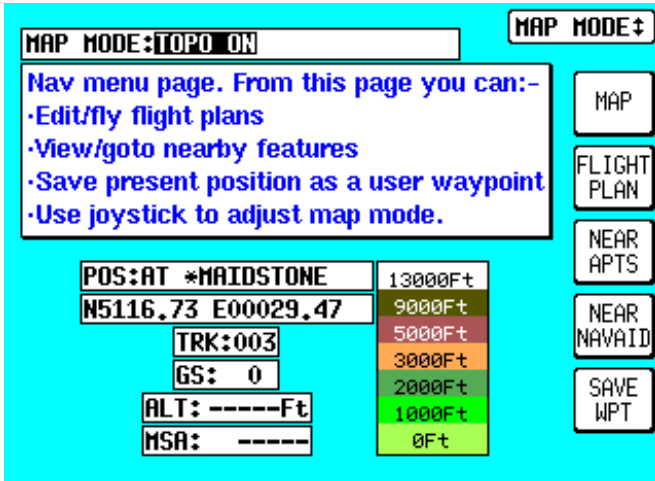

In all three modes there are a further two options which are either TOPO ON or TOPO OFF. In the TOPO ON mode all classes of data can be set to a specific colour. In the TOPO OFF mode all cartographic data is automatically removed and the Jeppesen NAV Data is presented on a black background.

The presentation style can be changed at any time by pressing the **NAV MENU** key in MAP mode. The joystick can then be toggled until the desired selection is shown in the MAP MODE field. CDI Map Mode will only be displayed when a **DIRECT TO** or flight plan is running. The

new selection can be viewed by pressing **MAP**. Also in the NAV MENU screen, a key is displayed showing the colour representation of ascending topographical elevations. The colours used to represent each elevation cannot be modified and vary between different regions, in the image above the Americas colour set is shown.

Viewing ETAs/Skip Waypoints

When a flight plan is running and the pointer is inactive, the ETA to each planned waypoint can be viewed by pressing the **DIRECT TO** key on the map.

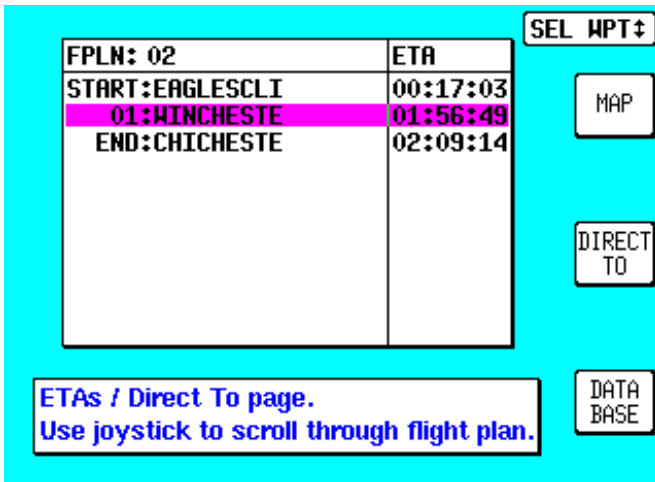

On entry to the adjacent screen the cursor highlights the waypoint in MAGENTA that is currently being navigated to. If ATC clear you to END: CHICHESTER, for example, you can use the Direct-To waypoint function to amend the routing quickly without having to edit the Flight Plan. Use the joystick to move a BLACK highlight over END: CHICHESTER, then press **DIRECT TO**. This function is not available in External GPS Mode.

Ten Nearest Search

The ten nearest airports or beacons can be displayed by either pressing **NAV MENU** or **DIRECT TO** in MAP mode, followed by either **NEAR APTS** (for airports) or **NEAR NAVAID** (for beacons).

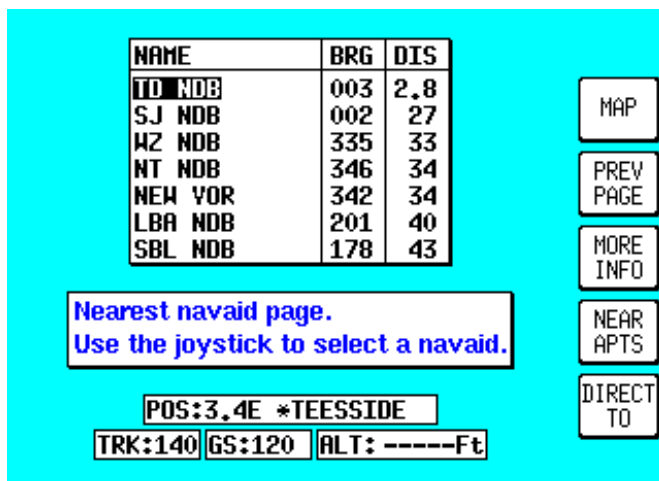

The desired information will be presented dynamically as a bearing and distance from your present position. Any displayed item can be instantly navigated to by pressing the **DIRECT TO** key. Alternatively the **MAP** key can be used to return the user to MAP mode.

SETUP MAP FUNCTIONS

When you receive the unit, it will be pre-programmed with default values for colour, language, map orientation etc. however it is possible to fully customise the map display for your specific operating requirements and taste.

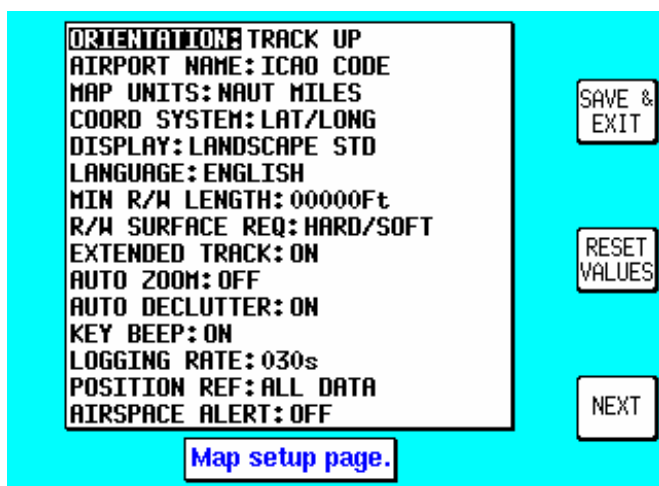

The initial screen is reached by pressing **SET UP** in MAIN MENU, followed by **MAP SETUP**. The subsequent screens are reached by pressing the **NEXT** key.

On the initial page, each of the displayed features can be set using the joystick. The features are as follows:

ORIENTATION: Set either in Track Up or North Up.

AIRPORT NAME: Labels airports in MAP mode either with ICAO code, airport or city names.

MAP UNITS: Sets all map units to either nautical miles, statute miles or kilometres. If miles are selected, all lengths and altitudes will be reported in feet. If kilometres are selected, all lengths and altitudes will be reported in metres.

COORD SYSTEM: Determines whether the unit operates with reference to Lat/Long, UTM or OSGB.

DISPLAY: Sets orientation of the display into one of four configurations.

LANGUAGE: Sets language to English, French, German or Spanish.

MIN R/W LENGTH: Sets the minimum length of runway required for ten nearest airports.

R/W SURFACE REQ: Sets the runway surface required for ten nearest airports.

EXTENDED TRACK: Turns on or off the extended track line, which is drawn ahead of your present position in the direction of your present track.

AUTO ZOOM: Turns on or off. When flying the last leg of a flight plan or when flying a DIRECT TO, as soon as the distance to the destination drops below ½ the scale bar setting, the unit automatically zooms. Auto Zoom can be disabled by simply pressing the ZOOM OUT key.

AUTO DECLUTTER: Turns on or off. If a higher priority icon label (Airport) is found to clash with a lower priority icon label (City) already on the screen, the lower priority icon label will be removed.

KEY BEEP: Turns the key beep on or off.

LOGGING RATE: Sets the rate in seconds at which you log your position and loads it into a 2000 point cyclic memory. To log a specific flight use the CLEAR LOG key in the Clear Memory screen (please refer to the Clear Memory section below). The flight can be replayed in DEMO MODE (please refer to the selecting DEMO MODE section above).

POSITION REF: Defines the reference to which your position is given in MAP MODE, either to all available data, VORs only or VORs and Airports only.

AIRSPACE ALERT: As the aircraft is about to cross an airspace boundary, a warning appears on the screen in MAP mode.

ITEM	ICON	TOPO		ICON NAME		
		ON	OFF	MAX	MAX	MIN
AIRPORTS	●	■	■	30	15	0.5
VORs	◇	■	■	30	15	0.5
NDBs	⊙	■	■	15	8	0.5
USER WPTs	◆	■	■	15	8	0.5
INTs	▲	■	■	OFF	OFF	0.5
VRPs	⊕	■	■	30	15	0.5
HELIPADS	⊕	■	OFF	OFF	OFF	0.5
HELIREPS	▲	■	OFF	OFF	OFF	0.5

SAVE & EXIT

RESET VALUES

NEXT

Next Screens 1, 2, 3 and 4 are accessed by repeatedly pressing the **NEXT** key. They allow you to choose the level of zoom at which you wish each of the classes of data to become visible and at which level of zoom you want their corresponding labels to become visible. You can also set the icon or line style for many of the data classes and set their display colours for both TOPO ON and TOPO OFF display modes.

ITEM	ICON	TOPO		ICON NAME		
		ON	OFF	MAX	MAX	MIN
GLIDERS	⊙	■	OFF	15	OFF	0.5
MICROS	⊙	■	OFF	15	OFF	0.5
PARACHUTE	⊙	■	OFF	15	OFF	0.5
CITIES	■	■	OFF	15	8	0.5
OBSTACLES	▲	■	■	30	8	0.5
AIRCRAFT	✈	N/A	N/A	N/A	N/A	N/A
LOG TRAIL	OFF	N/A	N/A	N/A	N/A	N/A

SAVE & EXIT

RESET VALUES

NEXT

The LOGGING RATE setting on the initial MAP SET UP screen governs the spacing of the LOG TRAIL marks. Turning the LOG TRAIL off will prevent the position dots from being displayed on the MAP, however the flight data will still be logged for playback or download to a PC.

Any changes made in any of these screens will be saved once the **SAVE & EXIT** key has been pressed. At any time the **RESET VALUES** key can be pressed to return your unit to the default settings on that particular screen.

ITEM	LINE	TOPO		LINE MAX	NAME MAX	MIN	SAVE & EXIT
		ON	OFF				
NEW ROUTES	---	■	■	OFF	OFF	0.5	RESET VALUES
MAJOR ROADS	==	■	N/A	15	8	0.5	
PRIME ROADS	—	■	N/A	8	4	0.5	
OTHER ROADS	---	■	N/A	4	3	0.5	
RAILROADS	+++	■	N/A	8	N/A	0.5	
RIVERS/LAKES	---	■	N/A	90	N/A	0.5	
V AIRWAYS	---	■	■	OFF	OFF	0.5	
TERRAIN	N/A	N/A	N/A	90	N/A	0.5	
SEA	N/A	■	N/A	N/A	N/A	N/A	
URBAN AREAS	N/A	■	N/A	N/A	N/A	N/A	
BACKGROUND	N/A	■	N/A	N/A	N/A	N/A	NEXT

If you wish to reset all setup options (including NAV SETUP options) to their default setting press the **CLEAR SETUP** key in Clear Memory screen after having entered the personal pin number. To navigate to the clear memory screen from the MAIN MENU, press the **INST & DIAGS** key.

Note: The content of the setup screens is dependant on which data card is installed. For example Victor Airways are only included in the AMR enhanced data card. The software will only show data classes that are available within the card database.

ITEM	TOPO		LINE MAX	NAME MAX	MIN	SAVE & EXIT
	ON	OFF				
FIR/UTR	■	■	50	30	30	RESET VALUES
CLASS A/B/C	■	■	30	15	0.5	
CLASS D	■	■	30	15	0.5	
CLASS E/F/G	■	■	OFF	OFF	0.5	
CLASS UNKNOWN	■	■	30	15	0.5	
DANGER	■	■	50	30	0.5	
RESTRICTED	■	■	50	30	0.5	
PROHIBITED	■	■	50	30	0.5	
MIL/MATZ	■	■	30	15	0.5	
OTHER SUA	■	■	50	30	0.5	

SETUP OF NAVIGATION FUNCTIONS

The following screen allows the navigation functions to be configured. It can be reached by pressing **SET UP** in MAIN MENU, followed by NAV SETUP.

CDI SCALE: 5.0nm	SAVE & EXIT
CDI DISPLAY: BAR	
CDI ALARM: OFF	
MPT ALERT: 01nm	
AUTO LEG SELECT: ON	
AUTO NEXT LEG: ON	
TURN ANTICIPATION: ON	
FLIGHT PLAN DISPLAY: ALL LEGS	
INTERNAL ALARM: OFF	
EXTERNAL ALARM: OFF	

Nav setup page.

Each of the displayed features can be set by using the joystick. They are as follows:

CDI SCALE: Sets the full-scale deflection of displayed CDI to 0.3, 1.0, 2.5 or 5.0nm.

CDI DISPLAY: Either turns the CDI display off, or sets it to either a numeric or bar display.

CDI ALARM: Switches the CDI alarm on or off. When on, the alarm is activated at full-scale deflection.

WPT ALERT: Sets the distance away from your destination waypoint at which you wish the audio and visual arrival alarms to be activated. This value is always in nautical miles.

AUTO LEG SELECT: When switched on, the unit will automatically determine which is the most appropriate leg to fly when calling up a flight plan.

AUTO NEXT LEG: When switched on, the unit will automatically sequence you on to the next waypoint in a flight plan when it has deemed that the current waypoint has been passed. When switched off the user will be expected to press the **NEXT LEG** key in MAP mode to sequence on to the next waypoint in the flight plan.

TURN ANTICIPATION: Turn Anticipation provides navigation along a curved path segment to ensure a smooth transition between two adjacent legs in the flight plan at higher groundspeeds.

FLIGHT PLAN DISPLAY: Allows a choice of displaying the full flight plan or just the active leg on the map screen.

INTERNAL (ARRIVAL and CDI) ALARM: These alarms can be switched on or off.

EXTERNAL (ARRIVAL and CDI) ALARM: These alarms can be switched on or off.

Any changes made in this screen will be saved once the **SAVE & EXIT** key has been pressed. At any time the **RESET VALUES** key can be pressed to return your unit to the default settings. If you wish to reset all setup options (including MAP SETUP options) to their default setting press the **CLEAR SETUP** key in the Clear Memory screen.

CLEAR MEMORY

To clear down specific parts of your units' memory press **SET UP** in MAIN MENU, followed by **INST & DIAGS** and **CLEAR MEMORY**. You will then be asked to enter you're your PIN (unit default is 1-2-3-4). You are now in the Clear Memory screen.

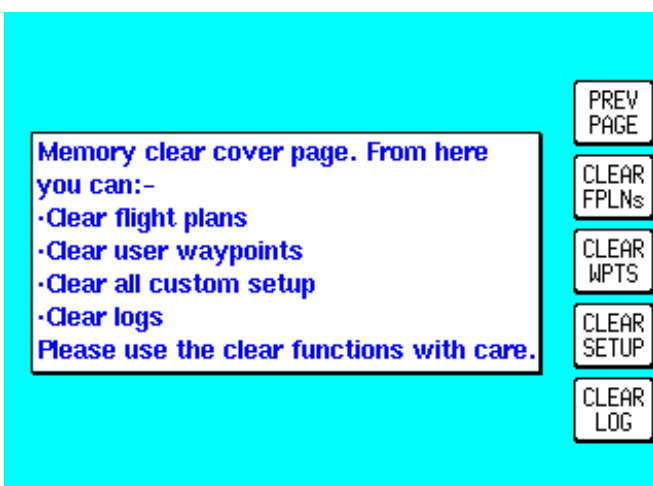

Each block of memory in your unit can be cleared down individually. **CLEAR FPLNs** will remove all your flight plans. **CLEAR WPTS** will remove all your user waypoints. **CLEAR SETUP** will restore all the default settings in MAP SETUP and NAV SETUP. **CLEAR LOG** will clear the last flight information, the 2000 logged flight data points and all running timers.

THIS PAGE INTENTIONALLY BLANK

SECTION 3 DETAILED OPERATION

TITLE AND HELP SCREENS

To switch the unit on, rotate the On/Off/Brightness control fully clockwise.

Your unit produces a variety of tones and alarms to assist you in correct operation. At this stage only two types of tone are relevant. These are:

- One short beep sounds when you press a valid key.
- Two short beeps sound when you press a key that is not assigned.

In the following screen images the numbers shown adjacent to the key positions indicate the screen number activated when that key is pressed.

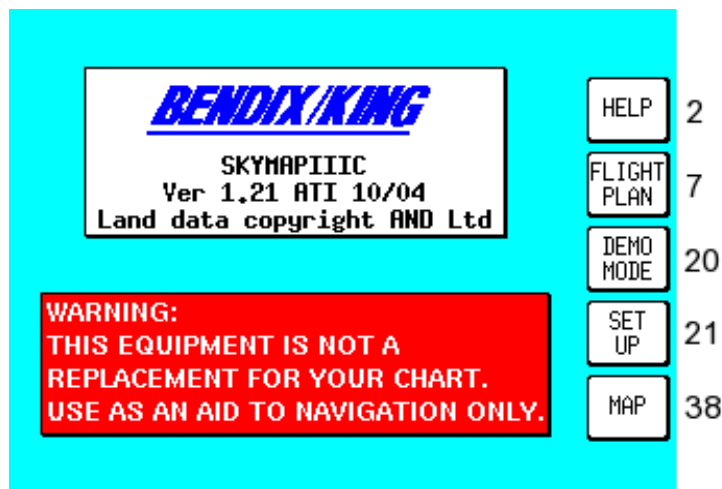

Screen 1: Title Screen

The Title Screen appears each time the unit is switched on, after the Jeppesen® database expiry date has been acknowledged.

- Key 1 calls Screen 2, which is the Main Menu Screen.
- Key 2 calls Screen 7, which is the Flight Planning Mode Cover Screen.
- Key 3 calls Screen 20, which is the Demo Mode Setup Screen. (If, since being switched on, the unit has received valid fix information from the internal GPS receiver (Skymap IIC) or from an external device (Tracker IIC), Key 3 DEMO MODE will for safety reasons be blanked and disabled.) This is the only Screen on which Demo Mode can be activated.
- Key 4 calls Screen 21, which is the Setup Cover Screen.
- Key 5 calls Screen 38, which is the Map Mode Screen.

To switch the unit off, rotate the On/Off/Brightness control fully counter clockwise.

WARNING: Do not force the control knob past its end stops.

Self Test and Initialisation

When the Title Screen is initially displayed, the unit carries out a series of internal check routines automatically. These are:

1. Verification that the unit has been factory initialised. This consists of a check to see if there is a special code in NVM. If there is no initialisation code in the NVM a message saying UNIT NOT INITIALISED will be printed across the centre of the Screen and the unit will be totally disabled. This is a security feature, safeguarding against theft of the unit and attempted erasure of your PIN from the NVM. (If your unit is stolen and the NVM is erased or replaced in an attempt to reset the PIN, the thief will still not be able to use or sell the unit because these special high security factory initialisation codes will be missing.)
2. A check for RAM corruption. If RAM has been lost or corrupted due to a severe 'glitch' or loss of power in the memory battery a RAM clear will be performed on the affected areas and Screen 51, Ram Lost Warning Screen, will be displayed (Refer to APPENDIX B).
3. A check of the internal Lithium battery voltage. If the internal battery voltage is low, Screen 52, Internal Battery Warning Screen, will be displayed (Refer to APPENDIX B).
4. A check to see whether the Automatic Power-On Lock function has been enabled (see Screen 26 for further details). If it is enabled, Screen 54, Power On Security PIN Entry Screen, will be displayed after 5 seconds (or if any Key is pressed before this). If when switched on it is found that three unsuccessful attempts have been made to enter the Unlock PIN, Screen 55, Lockout Screen, will be displayed (Refer to APPENDIX B).
5. A check to see if a new memory card has been fitted. This involves comparing the software version number held in NVM with that of the current memory Card. If a change of card is detected, the integrity of all flight plans will be checked and if any discrepancies are found Screen 56, Flight Plan Change Warning Screen, will be displayed (Refer to APPENDIX B).
6. If the unit is a Skymap IIIC the GPS receiver circuitry will be tested and if any problems are found, a NO REPLY message will be indicated in the STATUS field of Screen 3, GPS Status Screen.

If the unit passes all checks 1 to 6 above no warnings will be given

Main Menu Screen

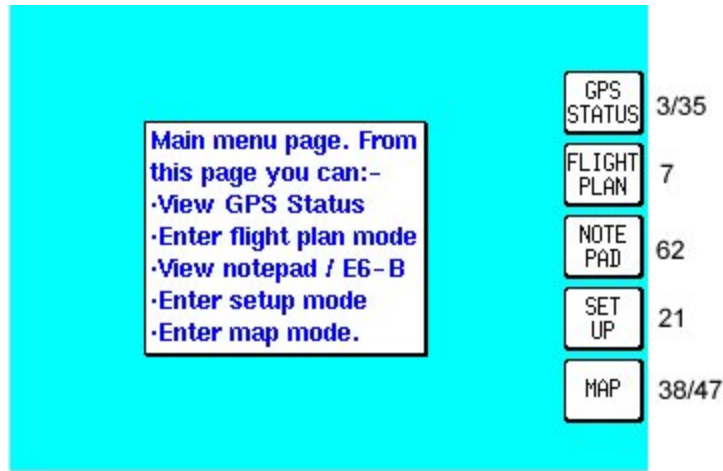

Screen 2: Main Menu Screen

On Skymap IIIC units, Key 1 calls Screen 3, which is the GPS Status Screen. On Tracker IIIC units, Key 1 is labelled DATA IN/OUT and will cause Screen 35, Data input/output Setup and Test Screen, to be displayed. Key 2 calls Screen 7, which is the Flight Planning Mode Cover Screen. Key 3 will read NOTE PAD if DEMO MODE was not selected on Screen 1. Pressing Key 3 when labelled NOTE PAD will call screen 62, which is the NOTE PAD display screen and will also give access to Screen 57, which is the E6-B Calculator Cover Screen (Refer to Section on E6-B Calculator). If Demo Mode has previously been activated, Key 3 will read DEMO OFF. Pressing DEMO OFF will then switch Demo Mode off and return to Screen 2 with Key 3 reading NOTE PAD. Key 4 calls Screen 21, which is the Setup Cover Screen. Key 5 calls Screen 38 or 47, which are MAP Mode and MAP Mode with NAV Information Screens.

Note Pad Screen

The Note Pad Screen (Screen 62) is accessed by pressing Key 3 on Screen 2, Main Menu Screen.

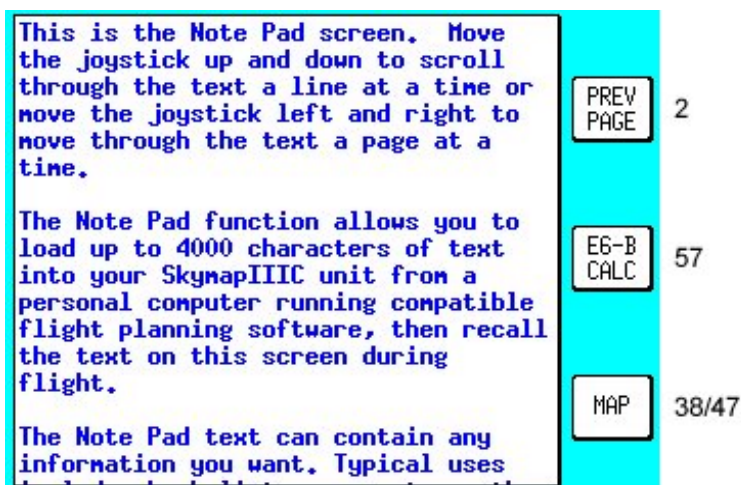

Screen 62: Notepad Screen

The Note Pad function allows you to load up to 4000 characters of text into your GPS unit from a personal computer running the 'Flight Manager' flight planning software, and then recalls the text on this screen during flight.

The Note Pad text can contain any information you want. Typical uses include checklists, en-route weather downloaded before the flight from DUATS, special instruction for an unfamiliar destination etc. Using the 'Flight Manager' software you can prepare and store a library of Note Pad files and load the relevant one into your Bendix/King unit to suit your day's flying.

Screen 62 also gives access to the E6-B calculator screens.

GPS STATUS SCREENS (SKYMAP IIIC ONLY)

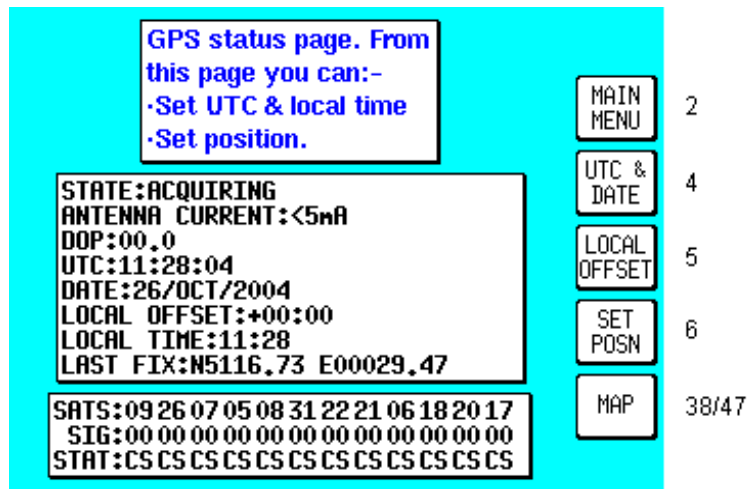

Screen 3: GPS Status Screen

Pressing Key 1, GPS STATUS, in Main Menu, accesses this Screen.

The GPS Status Screen will display the receiver status. This can be any of the following:

BAD ALMANAC	<3 SATS	DIFFERENTIAL	ACQUIRING
2D FIX	3D FIX	POOR DOP	POS PROP

The meanings of these displays are:

BAD ALMANAC means the GPS receiver's information concerning satellite positions is out of date. If this occurs the unit should be left alone with the antenna connected and in view of the sky for approximately 15 minutes during which period it will automatically lock onto a satellite and load an up-to-date almanac.

<3 SATS means that according to the current information available, there are less than three satellites in view and a fix can not be calculated. This message is very rarely displayed.

DIFFERENTIAL This word will be displayed in conjunction with 2D FIX or 3D FIX and means that the Skymap IIIC has a fix and is also receiving differential correction signals from an external source. (Refer to APPENDIX E for further details concerning differential operation.)

ACQUIRING means the unit is currently searching for satellites or is loading information from one or more satellites.

2D FIX means the unit is calculating position in two dimensions (i.e. latitude and longitude only, with no height information).

3D FIX means that the unit is calculating position in three dimensions and can give latitude, longitude and height information.

POOR DOP means that the unit is unable to calculate position owing to the poor geometry of the visible satellites. (DOP stands for Dilution of Precision.)

POS PROP means that navigation has been temporarily lost and the Skymap IIIC is dead-reckoning (or propagating) its position based on the last known position, track and ground speed. It will not dead-reckon for more than a few seconds at a time.

Other information that is displayed on this Screen includes:

DOP (Dilution of Precision), This is a number between 00.0 and 99.0 that represents the dilution of quality of the calculated fix due to satellite geometry. 00.0 is best, 99.9 is worst. If this figure is greater than 5.0, performance of the system is likely to be degraded because some of the visible satellites appear too close to each other. DOP is calculated from the angular separation between the various visible satellites. Greater separation results in better fix geometry and a lower DOP. (This DOP figure is not measured in any specific units.)

UTC/DATE, which is Universal or Greenwich Mean Time and Date.

LOCAL OFFSET, which is the difference between UTC and local time.

LOCAL TIME, which is calculated by adding Local Offset to UTC.

LAST FIX. If the unit does not have a current valid fix, this is the position at which it last had a fix. If the unit has a fix, this is the present position.

SATS (eight or twelve satellite numbers depending model), **SIGS** (signal strength for each satellite) and **STAT** (status of each satellite).

Each satellite has a PRN (Pseudo Random Noise) or identification number. The satellite PRN numbers are displayed in a line beside the word SATS. The two-digit number under each PRN number is an indication of the signal strength being received from that satellite expressed in terms of a percentage. Best is 99, worst is 00. These numbers can be used for finding and eliminating electrical interference. Readings of 60 and above indicate a good installation.

Under each signal strength number is a two-character code. These indicate the status of each satellite. These codes are: CS, CA, AS, FA, BD, MD, TA, EA, and AP. These relate to the eight possible receiver modes and are detailed below.

CS: Code Search. This is the receiver's initial stage in acquiring a satellite. It means that the receiver is trying to match its internal code to the satellite signal.

CA: Code Acquire. This means the satellite code has been received and matched to the receiver-generated code.

AS: AGC Set. This means the satellite strength has been assessed and the Automatic Gain Control has been set.

FA: Frequency Acquire. This means the receiver has correctly locked onto the satellite data frequency.

BD: Bit Sync Detect. This means the receiver is synchronised with the satellite's data bit stream.

MD: Message Detect. This means the receiver is synchronised with the satellite's message stream.

TA: Time Available. This means the satellite is fully locked in and has sent down UTC time and date information to the receiver.

EA: Ephemeris Acquire. This means the receiver is reading the constellation health status message from the satellite. This usually takes around two minutes and is a function that is performed in the background even if the receiver has a fix.

AP: Available for Position. This means the satellite is fully locked in and tested and can be used for calculating position. A minimum of three satellites are necessary for a 2D fix.

Key 1 returns to Main Menu.

Date, Time, Local Time Offset and Present Position can be adjusted by selecting one of Keys 2, 3 or 4. Direct access to the MAP Mode is available by pressing Key 5.

When using the Skymap IIIC for the first time (or after it has been relocated by more than 100 miles since it was last used) setting up the present position (to within 50 miles or so) and ensuring that UTC and Date are correct (to within a few minutes) will considerably speed up the TTFF (time to first fix). It is not absolutely necessary to do this, since given time, the receiver is quite capable of working out its own position.

Adjusting Time and Date

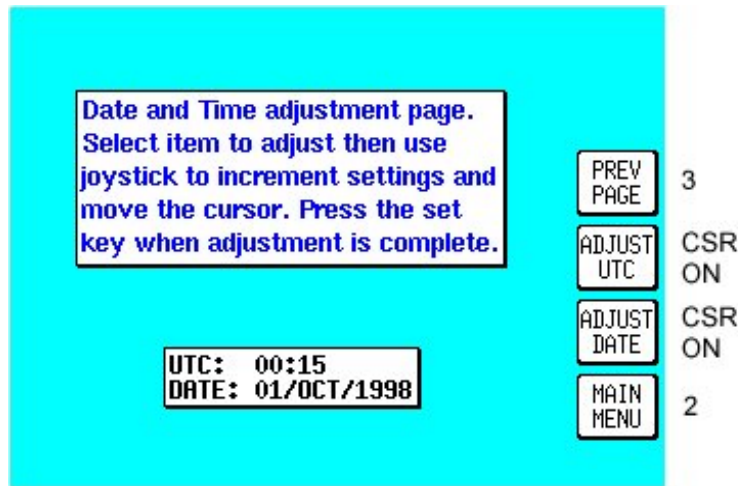

Screen 4: Date and Time Adjustment Screen

Pressing **GPS STATUS** in Main Menu followed by **UTC & DATE** accesses this Screen.

The **UTC & DATE** key will only be available if the GPS has not acquired the current date and time from a satellite.

Pressing Key 3, **ADJUST UTC**, places a cursor over the first digit of the Hours value on the time display. The value can then be increased or decreased by moving the joystick up or down. Pushing the joystick to the right then moves the cursor to the next digit. Similarly, moving the joystick to the left moves the cursor back along the data entry field.

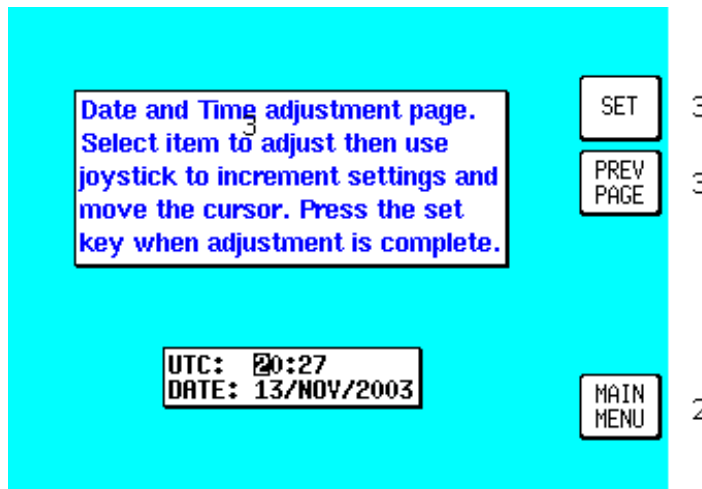

Screen 4 (Cursor On): Date and Time Adjustment Screen

When the time is adjusted, the information will only be saved if you press Key 1 **SET** as illustrated below.

Pressing Key 4 puts a cursor onto the Date entry field. The date is adjusted in the same way as time. With the cursor over the Month when the joystick is moved up or down, the first three characters of each month are scrolled together i.e. JAN, FEB, MAR, APR etc. Adjusting the year works in the same way. Your Bendix/King unit is fully Year 2000 compliant. The Time and Date will be automatically corrected as soon as the first satellite reaches TA (time available) status. If any satellite is already at status TA or above, user inputs of time and date will be ignored.

Setting Local Time Offset

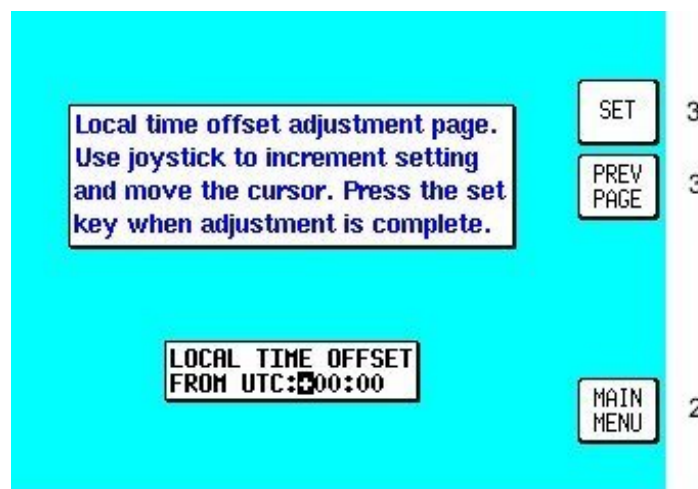

Screen 5: Local Time Offset Screen

Pressing GPS STATUS in Main Menu, followed by LOCAL OFFSET, accesses this Screen. When this Screen initially appears a cursor will be active in the data entry field.

The hour's value can be adjusted between the limits of +12 and -12 by using the joystick. The cursor can then be moved to the right to adjust the minutes to one of two values, 00 or 30. Only after pressing Key 1, SET is the information saved and the display will revert to Screen 3, GPS Status Screen.

The local offset is held in RAM and added to UTC time when calculating ETA's. Default value is +00:00. **It is important to set local offset correctly to ensure any ETA's given are correct.**

Setting Present Position

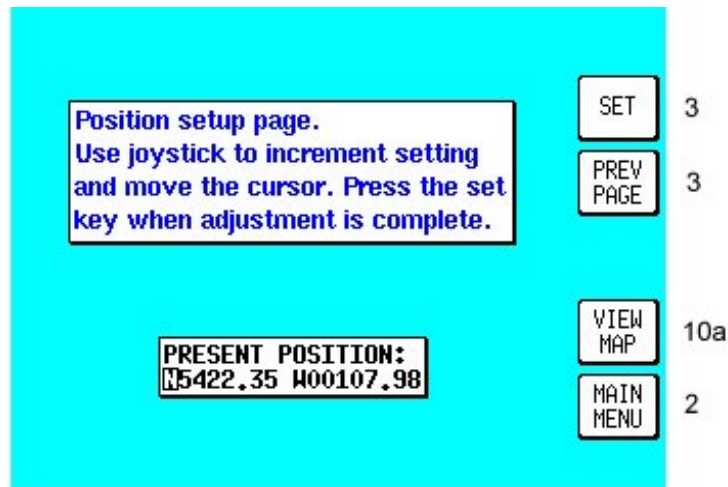

Screen 6: Present Position Setup Screen

Pressing **GPS STATUS** in Main Menu, followed by **SET POSN**, accesses this Screen.

The **SET POSN** key will not be available if the GPS has acquired a fix.

On entry to this Screen a cursor is positioned over the first character of the latitude as shown above. The joystick can then be used to increment or decrement values and to move the cursor right and left.

Alternatively you can press Key 4 VIEW MAP and using the joystick, simply point at your present position.

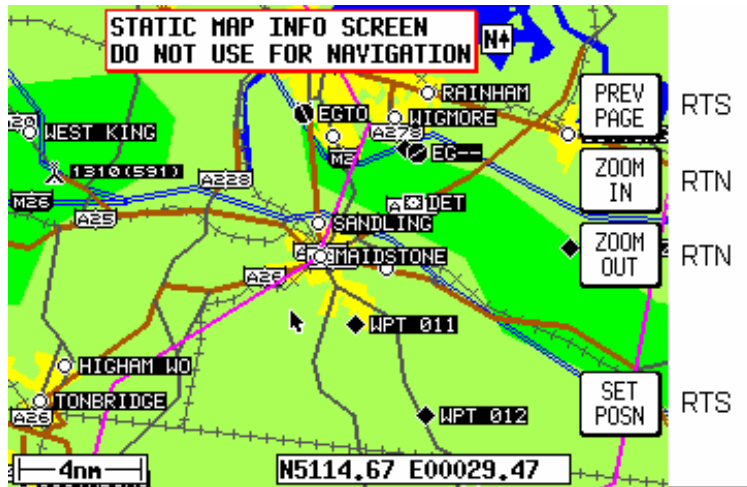

Screen 10A: View Map Screen

When Screen 10A is displayed you can zoom in or out using Keys 2 or 3. By using the joystick you can 'bump' the borders of the map window to view anywhere in the world. The POS: box at the bottom of the screen displays the latitude and longitude of the pointer.

Once you have the joystick pointing at your present location, press Key 5 SET POSN to return to Screen 3, GPS Status Screen. The pointer latitude and longitude will have become the LAST FIXED POSITION on Screen 3.

When new values for latitude and longitude have been selected numerically, pressing Key 1 SET will enter the new latitude and longitude and revert to Screen 3. If the unit is receiving sufficient satellite signals to calculate a fix, user-entered latitude and longitude will be ignored. Keys 3 and 4 give direct access to Time and Date adjustment.

DATA INPUT

The Tracker IIIC has no internal GPS receiver and so requires a data input from a separate GPS or LORAN unit in order to function in Map Mode. If required, the Skymap IIIC can also be run in Tracker mode using an external GPS or LORAN unit. (Refer to Data In/Out in the Setup Screens Section of the Manual). The following text is valid for Skymap IIIC also if set to Tracker mode.

Your Tracker IIIC unit is supplied complete with a power/data cable, which has red, blue, yellow and green cores and a braided screen. The red and blue cores are for connection to an external DC power supply rated between 10V and 33V. The yellow core is the data input cable for connection to your GPS or LORAN.

To operate correctly Tracker IIIC requires a 1200, 4800 or 9600 baud NMEA 0183 data sentence containing latitude, longitude, track, and ground speed information. This can take the form of a single RMC sentence or a combination of GGA and VTG sentences. Alternatively a 1200, 4800 or 9600 baud Trimble TNL, Garmin AIU or King equivalent ARNAV R-30 sentence may be used. A third alternative data input is the Northstar M3 binary data format at 1200 baud.

To connect the Tracker IIIC to the GPS or LORAN source unit strip the outer cable insulation back a short way and pull back the screening braid to reveal the four inner plastic covered cores. The screening braid of the cable should be twisted into a single core. The red and blue cables should be connected to an external power supply (red is +ve). The screening braid and blue cable core should be connected to the same –ve power supply as the GPS/LORAN. This provides a return path for the data output. You are now ready to make data connection to your GPS or LORAN unit. The input is RS232, RS422 and NMEA 0183 compatible.

When connecting to an RS232 or NMEA device, yellow should go to DATA OUT (A line). When connecting to an RS422 device, yellow should go to TX-. **Do not connect to RS422 TX +.**

Example 1: To connect to a Bendix/King KLN89/89B (RS232), connect the yellow core of the Tracker IIIC cable to pin 2 of the KLN device. Connect the blue core and screen of the Tracker IIIC cable are connected to the to the same –ve supply or A/C ground as pin 14 of the KLN device.

Example 2: To connect to a Bendix/King KLN90/90B (RS232), connect the yellow core of the Tracker IIIC cable to pin 13 of the KLN device. Ensure the blue core and screen of the Tracker IIIC cable are connected to the to the same –ve supply or A/C ground as pin 27 of the KLN device.

Example 3: To connect to a Garmin GPS150/155 (RS232), connect the yellow core of the Tracker IIIC cable to pin 19 (channel 1) or pin 24 (channel 2) of the Garmin device. Ensure the blue core and screen of the Tracker IIIC cable are connected to the to the same –ve supply or A/C ground as pin 26 of the Garmin device.

Example 4: To connect to a stand-alone Pronav or Garmin GPS 100 (NMEA), connect the yellow core of the Tracker IIIC cable to the yellow core of the power/data cable. Ensure the blue core and screen of the Tracker IIIC cable are connected to the same –ve supply or A/C ground as the black core of the power/data cable of the GPS.

Once you have made the physical connection to your GPS or LORAN **it is essential to select an appropriate data output.** This can be done by referring to the manual for your GPS/LORAN and choosing an option that corresponds to one of the compatible data input

types listed above.

Once a suitable data output type has been selected on your GPS/LORAN and it has a fix, switch on your Tracker IIIC and from the Main Menu Screen, press Key 1, **DATA IN/OUT**. Screen 35(T), Data input/output Setup and Test Screen will be displayed.

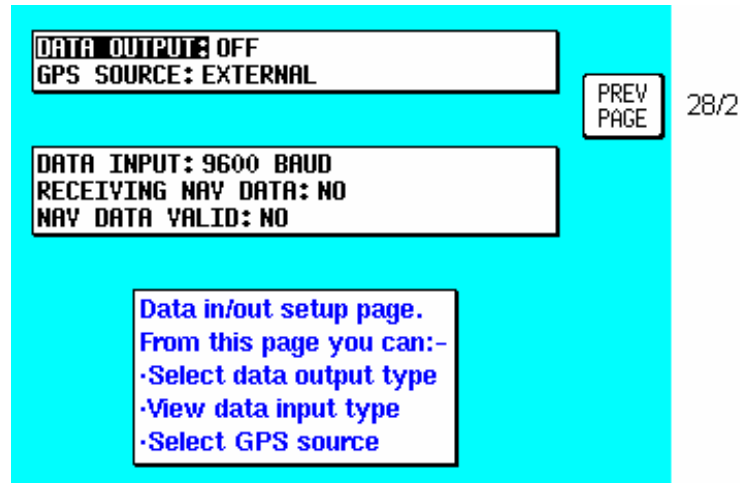

Screen 35(T): Data Input/Output Setup and Test Screen

If your GPS or LORAN is correctly connected, switched on and outputting data, your Tracker IIIC will automatically start to read and decode the incoming data. There is no need to set an input type on the Tracker IIIC as this is done automatically.

After a few seconds if data is being received, the word YES will appear next to the RECEIVING NAV DATA: heading. The type of data being received will then be displayed beside the DATA INPUT: heading.

If the data being received contains valid fix information (i.e. your GPS or LORAN has a fix) the word YES will appear next to the NAV DATA VALID: heading. Once the unit is receiving and validating the incoming data you are ready to navigate using Tracker IIIC 's advanced features.

Press Key 1, PREV PAGE, to return to either the Installation & diagnostics Cover Screen or the Main Menu Screen.

FLIGHT PLANNING SCREENS

In order to allow you to navigate along pre-planned flight plans, your Bendix/King equipment has facilities to memorise up to 500 user waypoints. Using these user waypoints together with the enormous built-in database you can then plan up to 99 flight plans. The equipment has a capacity to store up to 500 flight plan points with a maximum number of waypoints in any one flight plan of 99.

For example, you can program 99 flight plans, each with 5 waypoints making a total of just under 500 flight plan waypoints or you could program 5 flight plans each with 99 waypoints. If you attempt to exceed 500 waypoints the unit will display a FLIGHT PLANS FULL message.

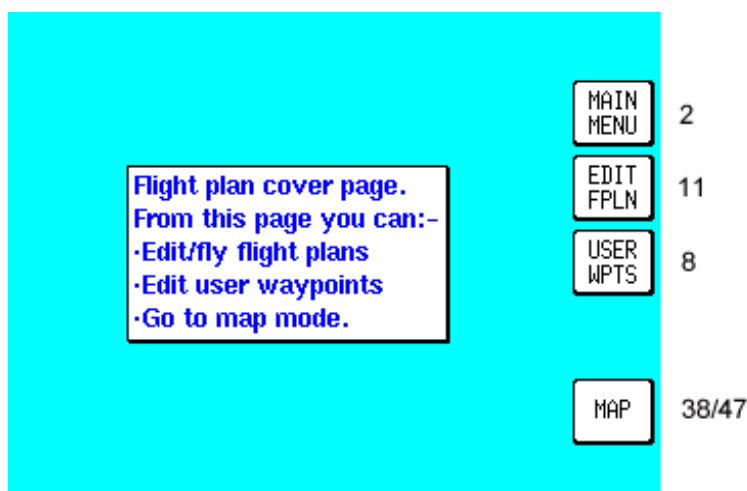

Screen 7: Flight Planning Mode Cover Screen

Pressing Key 2, FLIGHT PLAN, in Main Menu, accesses this Screen.

Key 1 returns to Main Menu.

Key 2 EDIT FPLN, gives access to flight plan creation and editing pages.

Key 3 USER WPTS, gives access to user waypoint creation and editing pages.

Key 4 has no function.

Key 5 gives direct access to the current MAP Mode.

For simple single-leg navigation there is a useful “goto” or DIRECT TO navigation mode. This allows you to fly from your present position directly to any point in the world. More details about this function are discussed in the Map Mode Screens Section of this Manual.

All user waypoints and flight plans are normally programmed before embarking on the trip and stored in the unit's user waypoint and flight plan library.

User Waypoints

A user waypoint is a specific location anywhere in the world, defined by an icon, a name of up to nine letters or numbers and by a latitude and longitude. In your new Bendix/King equipment there are three types of user-defined user waypoints, each with a specific function.

Basic User Waypoints are purely user-defined points. These are used in flight plan

building, along with data points from the internal database, or simply to add personalised points to your map. A large choice of icon styles are available.

Marker User Waypoints are also user-defined waypoints. These can be configured to act as alarm trigger markers. For example, say you are flying a flight plan and you know you have to make a radio call or initiate a climb at a specific point. A Marker User Waypoint can be positioned at that location (but not included in the flight plan) and be set up to trigger an alarm. If a user waypoint is to be used as an alarm trigger, when it is programmed it is given the name **MARKERX.X** (by pressing the MARKER key). The word MARKER here notifies the software that this user waypoint is to be used as a marker point only and that no name is to be printed next to the user waypoint icon on the map. The X.X specifies the alarm trigger distance between 0.1nm and 9.9nm. The default is 1.0nm. A circle of the specified radius will appear around the marker point on the map.

Whilst the Bendix/King software is searching to locate the nearest items for conventional position reporting, if it pulls up a user waypoint named MARKERX.X, it will continuously compare the distance from the present position to the Marker waypoint with the value X.X. When the distance to the Marker becomes less than or equal to X.X then an audible alarm will be triggered. A box will also appear at the top of the screen showing MARKER IMMINENT. Key 5 will change to ALARM OFF and when pressed, will silence the audio alarm and remove the MARKER IMMINENT message.

Should you wish a Marker waypoint to have a name next to it for reference, you simply program a Basic User Waypoint with the same co-ordinates as the Marker and give this one a conventional name. The User and Marker waypoint icons would then be superimposed on each other, resulting in a single, named, waypoint.

User Defined Airports. Owing to the fact that many private and unlicensed airports are not included within the Jeppesen database contained within your unit, you have the opportunity to program up to 25 of your own USER DEFINED AIRPORTS. User waypoints numbered 101 - 125 have been reserved for this purpose and whenever any of these is selected for editing on Screen 8, User Waypoint Viewer Screen, then Screen 8A will be displayed instead. This Screen allows the insertion of additional information, so permitting 25 user waypoints to become user-defined airports. These will be shown on the map pages with an airport icon instead of a user waypoint icon. The user-defined airports will also be included in the ten nearest airports search on Screen 43, Ten Nearest Airports Screen, and will receive equal priority with other database airports for position reporting purposes.

On Screen 39, MAP Mode with Joystick Active Screen, if the pointer is placed over a user-defined airport and the MORE INFO Key is pressed, Screen 40, Map Mode Airport Information Screen, will be displayed with the data you have entered being displayed.

Viewing User Waypoints

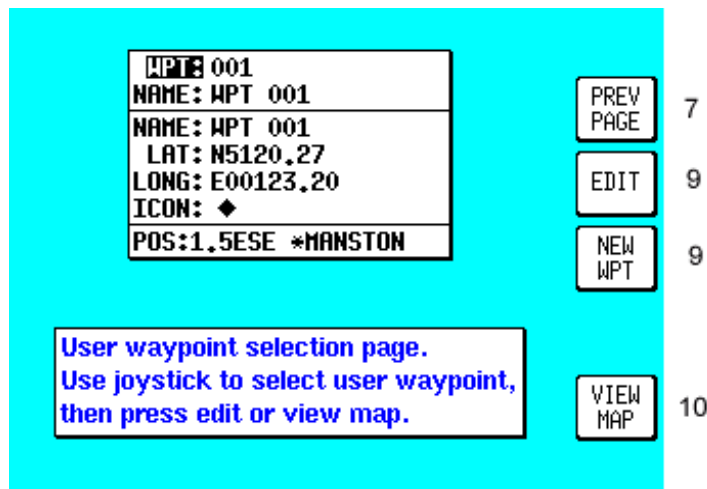

Screen 8: User Waypoint Viewer Screen

Pressing FLIGHT PLAN in Main Menu, followed by USER WPTS, accesses this Screen. When this Screen appears a cursor will be seen positioned over the WPT field. Use the joystick to increment or decrement the user waypoint number. (Holding the joystick up or down will increase the speed of these changes.) Alternatively the joystick can be used to select a user waypoint alphabetically by name in a similar fashion by moving the cursor down to the NAME: field.

As each user waypoint is selected, the name, latitude, longitude, icon and position fields are updated. Empty user waypoints will be shown with dashes in the latitude and longitude fields and the default icon (see Screen 22A, Point Features Data Class Setup Screen, in the Setup Screens Section of this Manual for details on setting up the default icon style).

As each user waypoint is selected, all stored flight plans are automatically checked to see if that user waypoint is being used in any current flight plan. If the user waypoint is found within any of the flight plans, the words [FPLN LINK] will be printed next to the user waypoint number. **It is necessary to think carefully before editing any user waypoint marked FPLN LINK** since any changes you make to the user waypoint may also affect one or more of the programmed flight plans.

If a user waypoint marked FPLN LINK is selected for editing and the **Name only** is changed, the new name will be copied over to the relevant parts of the flight plan list. If the name is left the same and the **Latitude and/or Longitude only** is changed, the new details will also be copied into the flight plan list. However, if the **Name** is changed, **along with either the Latitude or Longitude** the user waypoint will be treated as completely new and the details **will not** be copied to the flight plan list.

This would result in your being left with waypoints in your flight plans that do not exist as user waypoints. This can be beneficial in some cases as it makes it possible to double the number of user points in the system to 1000, but it is essential to understand this feature thoroughly and to use it carefully.

Once a user waypoint has been selected, Key 2 gives access to the Manual User Waypoint Editing facilities. Key 1 will return to the main Flight Planning Mode Cover Screen. Key 3, NEW WPT shall invoke the Manual User waypoint editing with the next available empty waypoint. NOTE: Key 3 is blank if the waypoint database is full. Key 5

displays Screen 10, which is the Graphical User Waypoint Editing Screen. This shows a map on which the selected user waypoint is central. If the selected user waypoint is empty, the map will default to the last fix position.

Manual User Waypoint Editing

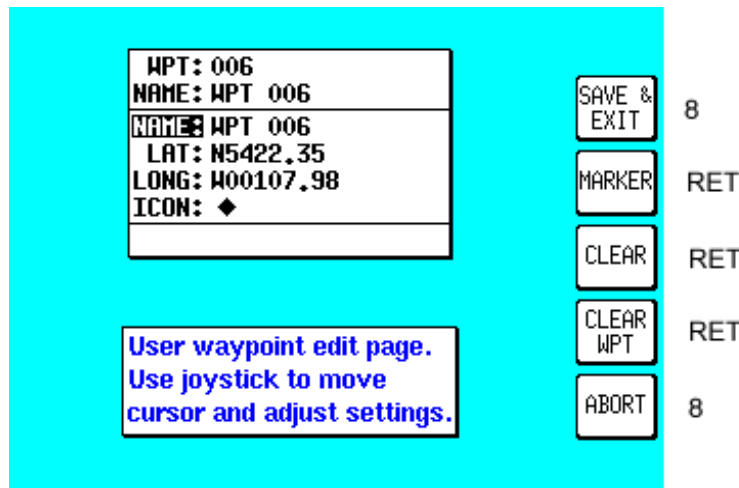

Screen 9: Manual User Waypoint Edit Screen

Pressing FLIGHT PLAN in Main Menu, followed by USER WPTS and EDIT, accesses this Screen. On entry to this Screen a cursor appears over the word NAME. The cursor can be moved up and down between NAME, LAT, LONG and ICON using the joystick. The joystick is used to move the cursor to the right so that the user waypoint name, latitude, longitude and icon type can be entered or amended, again by using the joystick.

When the cursor is moved to the right after the last character in a line the cursor will move to the next line heading. i.e. from the last character in the name, the cursor will go to the word LAT and similarly from the last digit of the longitude it will go to the word ICON.

If you want to use the selected user waypoint as a marker as described previously, pressing Key 2, MARKER, will automatically write the word MARKER1.0 into the name field. You can then move the cursor across using the joystick and alter the distance and fill in the latitude and longitude. If you want to delete an existing user waypoint, press Key 4. If you want to delete just the data entry field that the cursor is positioned over, press Key 3, CLEAR.

When the desired alterations have all been made, touching Key 1, SAVE & EXIT, will enter the revised data and return you to Screen 8, User Waypoint Viewer Screen. Alternatively, touching Key 5, ABORT, will return you to Screen 8 without modifying the user waypoint information, cancelling all the changes you have made.

Graphical User Waypoint Editing



Screen 10: View and Edit User Waypoints on the Map Screen

When this Screen first appears, after pressing VIEW MAP on Screen 8, User Waypoint Viewer Screen, the selected user waypoint will be centrally positioned. The joystick can be used to move the pointer. The screen window can be moved around to display other areas of the map by “bumping” the screen borders left, right, up or down with the pointer. If you need to “bump” the screen over a large distance you will find it quicker and easier to zoom out first, move across the map as required, then zoom back in. In order to make these moves swiftly, not all details of the map are shown on screen until the joystick is released.

Distance and bearing boxes below the map show distance and bearing from the selected user waypoint (or the last user waypoint entered) to the pointer. This feature allows you easily to enter new user waypoints as a distance and bearing from a previously entered user waypoint.

New user waypoints can be created wherever the pointer is placed, simply by pressing Key 2, ENTER WPT. Positioning the pointer directly over an icon and then pressing Key 5, DELETE WPT, will delete existing user waypoints. Should you attempt to delete a user waypoint that is being used in a stored flight plan, the [PRESENT IN FLIGHT PLAN] message box will be displayed and the user waypoint will NOT be deleted. Pressing Key 5, DELETE WPT, a second time **will** then delete the user waypoint. Alternatively if you move the joystick, the [PRESENT IN FPLN] message will be removed without deleting the user waypoint. Key 1, PREV PAGE returns to the screen entered from, saving any changes made.

Each new user waypoint graphically created on the map will automatically be given the next available user waypoint number as a temporary name and the default icon but you can alter the name and icon later by using Screen 9, Manual User Waypoint Edit Screen.

Editing User Airports

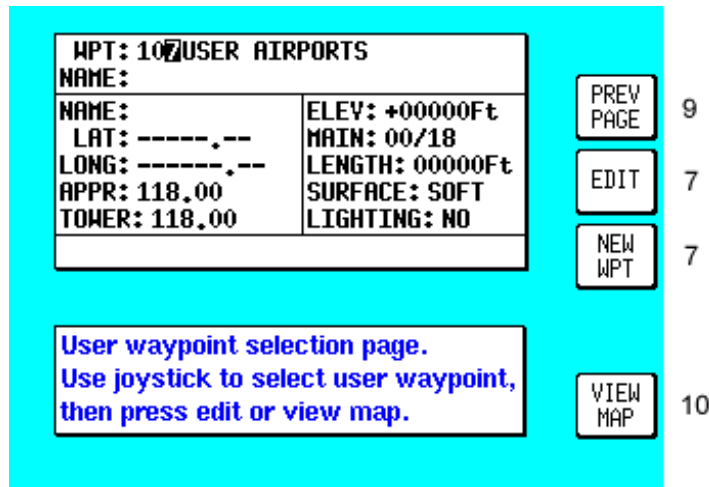

Screen 8A: User Airport Edit Screen

Whenever you select a user waypoint number between 101 and 125 in Screen 8, User Waypoint Viewer, Screen 8A User Airport Edit will be displayed. This is similar to Screen 8 but contains data entry fields where you can enter and store additional information about the airport's main runway and frequencies.

Flight Plans

The flight plan function allows you to store up to 99 flight plans, as explained earlier in this section. These flight plans can be recalled from memory and flown in Navigation Mode. You can choose to use any waypoints from the built-in database (which is subdivided and arranged alphabetically) and also, if you wish, from your own list of user waypoints.

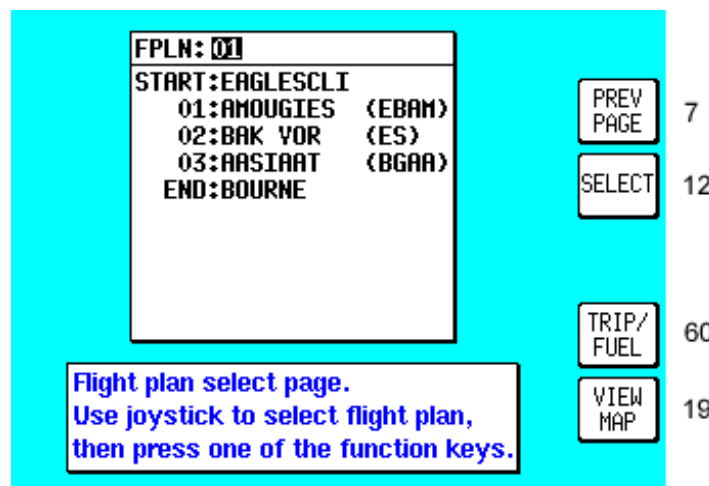

Screen 11: Flight Plan Selection Screen

Pressing FLIGHT PLAN in Main Menu, followed by EDIT FPLN, accesses this Screen. As you enter this Screen you will find a cursor positioned over the flight plan number. The first few items of the selected flight plan are displayed in the box under the flight plan number together with the final (destination) item. You can then use the joystick to select other flight plans. Use the same technique as described earlier for selecting user waypoint

numbers. Once you have selected the flight plan you wish to edit, pressing Key 2, will allow you to manually edit it.

Key 1, PREV PAGE, returns you to the Flight Planning Mode Cover Screen. Key 5, VIEW MAP, calls Screen 19, enabling you to edit the selected flight plan graphically on the map.

Key 4, TRIP/FUEL gives access to the trip and fuel planning function. For more information on this function please refer to the Trip/Fuel Planning information in the E6B Calculator Section of this Manual.

If you access the above Flight Plan Selection Screen while a flight plan is active, the active flight plan number is automatically displayed and you will find Key 5 has changed to FPLN OFF and Key 2 is blank. As a safety measure the system will not allow you to edit the active flight plan directly unless you touch Key 5, FPLN OFF. This will switch the flight plan out of active status and re-enable Key 2 allowing you to edit what was until then the active flight plan.

Manual Flight Plan Building and Editing

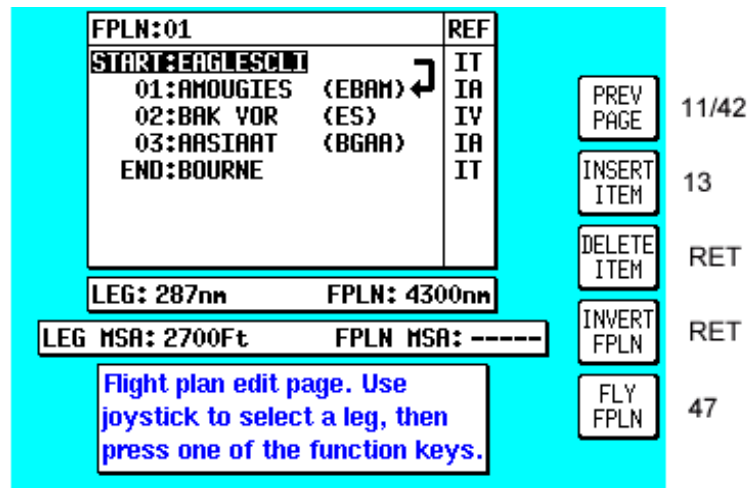

Screen 12: Flight Plan Program/Edit Screen

This Screen can be accessed either through the Flight Planning Mode Cover Screen (by pressing FLIGHT PLAN in Main Menu followed by EDIT FPLN and SELECT) or through the NAV Menu Cover Screen (by pressing NAV MENU in MAP Mode followed by FLIGHT PLAN). For more information on the second form of entry to this Screen see Screen 41, NAV Menu Cover Screen, in the NAV Menu Screens Section of this Manual.

When you enter this Screen you will find a cursor positioned over the first item in the chosen flight plan. By using the joystick, you can move the cursor up or down. This enables you to scroll in either direction through the entire flight plan in the display box.

Next to each waypoint in the column headed REF you will see a two-character code, which gives the database origin of each point in the flight plan. The meanings of these codes are as follows:

IA (Internal Jeppesen Airports); IV (Internal Jeppesen VOR's); IN (Internal Jeppesen NDB's); IR (Internal Jeppesen Runways); IT (Internal Towns); II (Internal Jeppesen Intersections/Approach Waypoints); WP (current user waypoint {if user waypoint link is present}); OW (Old user waypoint {if user waypoint link has been broken}); UA (User Airport {user waypoint numbers 101-125}) and PC (external data downloaded from a PC).

In the example shown in the illustration for Screen 12, moving the joystick down would move the cursor down over 01 (or Waypoint 1) but would leave the “LEG” arrow positioned as it was. The distance shown next to the word LEG also would remain unchanged, showing the leg distance from the flight plan start point to Waypoint 01 (01). Moving the joystick down again would move the cursor down to 02, move the leg arrow down so that it is pointing between 01 and 02 and the figures next to the word LEG would then show the distance from 01 to 02 and so on. The number next to the word FPLN is the total flight plan length from start to finish.

In addition, as the cursor is moved up and down the flight plan, the MSA for that leg is shown in a box below the LEG and FPLN info box as [LEG MSA: XXXX]. This value is the highest Grid MORA found along a ten-mile wide corridor (including five miles past the waypoint) centred along each leg. Also shown is the [FPLN MSA: XXXX], which is the highest value leg MSA for the entire flight plan.

An extra waypoint can be inserted at any place in the flight plan (assuming the flight plan is not full). To do this, you position the cursor over the appropriate point in the flight plan and press Key 2, INSERT ITEM. For example, if you placed the cursor over 02, the new item would become 02 and the existing 02 would become 03, etc. In a similar manner items may be deleted from the flight plan by positioning the cursor and pressing Key 3, DELETE ITEM. Key 4 inverts or reverses the flight plan. Key 5, FLY FPLN, throws the unit into Map Mode (Screen 47) with the selected flight plan active.

Manually Inserting a Waypoint into a Flight Plan and Manual DIRECT TO

A Waypoint can be inserted into a flight plan by using a two-step process, which is started by pressing Key 2, INSERT ITEM. The same process is followed when Key 5, DIRECT TO is selected in Screen 38, MAP Mode when the joystick is not active.

Step 1. Selecting data source

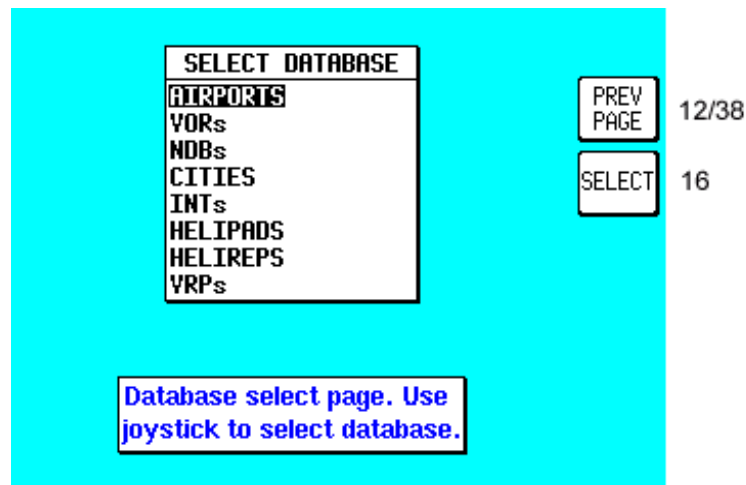

Screen 13: Database Selection Screen

This Screen shows a list of data libraries and you will find a cursor positioned over the word AIRPORTS. You can use the joystick to move the cursor up and down the list of databases. Keys 3, 4 and 5 only appear if this Screen is called from Screen 38, MAP Mode as a DIRECT TO.

By moving the cursor you select the database that contains the item you are looking for, whether to insert into your flight plan or to use as a DIRECT TO destination. Once you

DETAILED OPERATION

have the cursor over the correct database, pressing Key 2, SELECT, will move you onto the next selection process, which is Screen 16, Item Selection.

As stated above, Key 3, NEAR APTS and Key 4, NEAR NAVAID, only appear if this Screen has been entered after performing a DIRECT TO in Screen 38, Map Mode. For more information on the function of these keys, please refer to the “Ten Nearest” under the NAV Menu Screens Section in this Manual.

Also as stated above, Key 5, TEMP WPT, only appears if this Screen has been entered after performing a DIRECT TO in Screen 38, MAP Mode. If you press Key 5, this will take you to Screen 15 (see below), which allows you to enter a DIRECT TO point.

If Key 1, PREV PAGE, is pressed to discontinue the selection process the unit will return to whichever the previous Screen was, Screen 12, Flight Plan Program / Edit Screen, or Screen 38, MAP Mode.

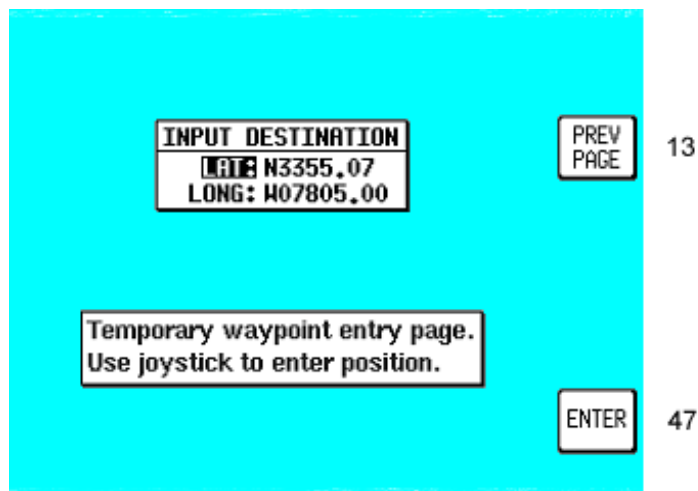

Screen 15: DIRECT TO Destination Input Screen

This Screen allows you to select a DIRECT TO specific latitude and longitude, and is reached by pressing Key 5 TEMP WPT on Screen 13.

Use the joystick to enter the latitude and longitude of the destination then press Key 5, ENTER, and Screen 47, Map Mode with Navigation Information, will appear with DIRECT TO OFF on Key 5.

Step 2. Selecting item from chosen database

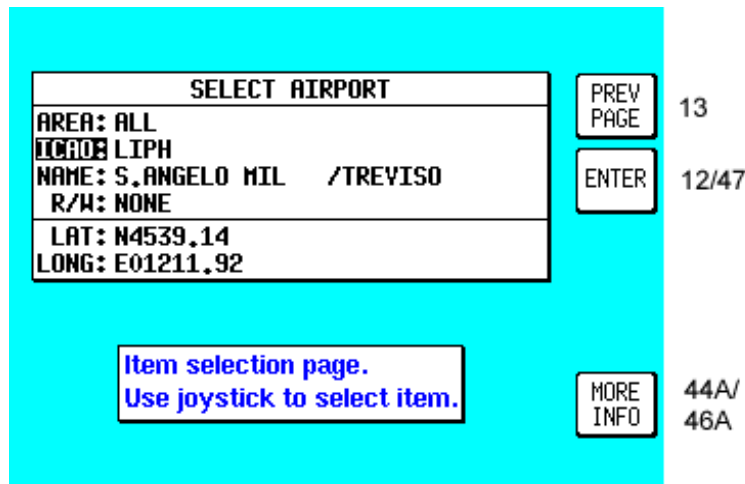

Screen 16: Item Selection Screen

On entry to this Screen you will find the cursor positioned over the first letter of the first item in the selected database.

If AIRPORTS, VORs, NDBs, INTs or AIRWAYS was selected on Screen 13, the first item in the data entry box on screen 16 is AREA:. This is an area filter, which can be set to a specific ICAO country or area code. If set to EG for example, only items in British airspace will appear in the list. Similarly, if set to LF, only items in French airspace will be displayed. In the USA, the airspace is sub-divided into seven areas known as K1 – K7. The area filter can again be set to any of these areas (see APPENDIX C for a full list of country and area codes).

If the area filter is set to ALL DATA, all the data from the selected database contained on the memory card for the entire area covered will appear in the list.

If AIRPORTS was selected on Screen 13 the cursor will be positioned over the word ICAO:. Airports may be selected by ICAO code, airport name or associated city name and in addition, once an airport has been selected, a particular runway threshold at that airport can be selected. If you wish to select an airport by name or associated city name, use the joystick to move the cursor down to name then right to the first character. If you wish to select a specific runway threshold, move the cursor down to R/W then right to the word NONE. Moving the joystick up or down will now allow you to select a specific runway threshold (if threshold information is available for that airport in the Jeppesen database).

When selecting names, use the joystick to scroll the initial letters through the alphabet. Once the required initial letter has been selected, move the joystick to the right and repeat the process. In this way you can scroll through all the items from the selected database, narrowing your search field. If you move the joystick to the left, the cursor will also move left one step, allowing you to make another selection.

On this Screen, Key 5 labelled MORE INFO gives additional information about the selected item.

When an airport is selected but no runway, the entry into your flight plan will be the name displayed followed by the airport's ICAO code. When a runway is selected, the entry into your flight plan will be the airport's ICAO code followed by the runway ident. For example, if you select runway 32L at Goodwood, the entry to your flight plan would be EGHR 32L.

Once you have reached the desired item, pressing Key 1, ENTER, will select it and either return you to Screen 12, Flight Plan Program / Edit Screen, entering the item to your flight plan or invoke the DIRECT TO and take you to Screen 47, MAP Mode with NAV Information, depending on which entry flight plan to Screen 13 you happen to have used.

If VOR's, NDB's or intersections / approach waypoints were selected on Screen 13, Database Selection Screen, you will see a two-letter ICAO area code displayed to the right of the identifier. If you have the area filter set to ALL, you can move the cursor over to the two-letter ICAO code and select items with similar names in other areas. For example, there are four NDB's in the Europe area with the indent 'AB'. To select any one of these, first select AB then move the cursor to the right so that it is positioned over the two-letter ICAO code. By moving the joystick up and down is it now possible to select EK, ES, LF or LO as a country code. By doing this you can select the 'AB' NDB in Finland (EK), Sweden (ES), France (LF) and Austria (LO).

When selecting a beacon, intersection or approach waypoint, check the ICAO area code carefully since there are many duplicates present in the database. Checking the area code will eliminate any ambiguity.

Graphical Viewing and Editing of Flight Plans

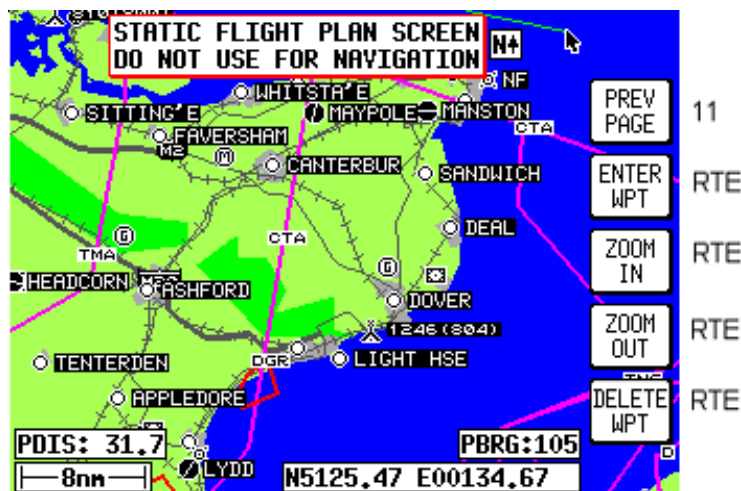

Screen 19: View and Edit Flight Plans On Map Screen

This Screen is accessed by pressing FLIGHT PLAN in Main Menu, followed by EDIT FPLN and Key 5, View Map, on Screen 11, Flight Plan Selection Screen. Screen 19 is displayed showing the starting point of the selected flight plan centred in the middle of the display. The legs and waypoints are shown as in the illustration above.

The joystick can be used to move the pointer. The screen window can be moved around the map by “bumping” the screen borders left, right, up or down with the pointer. **Distance and bearing boxes below the map show distance and bearing from the last waypoint in the flight plan to the pointer.** This feature allows you to enter waypoints as a distance and bearing from the previous flight plan point.

To build a flight plan you simply point at the first item to be included in the flight plan and press Key 2, ADD WPT (or **ADD WayPoint**). This will place an S (for Start) next to the waypoint. If no suitable data point or user waypoint is available beneath the pointer, a new user waypoint will be created; which can be given a name later by using Screen 9, Manual

User Waypoint Edit Screen.

Now move the pointer to the second item in the flight plan and press Key 2, ADD WPT. This will place an E (for End) next to the waypoint. To systematically create additional legs, draw a line from the waypoint marked (E), with the pointer, to the next waypoint and press ADD WPT again. You will notice that the last point in the flight plan will always be labelled (E). Once you have finished building the flight plan press PREV PAGE, this will detach the pointer from the flight plan. Press PREV PAGE again to return to screen entered from, saving any changes made.

If you wish to add a new waypoint to a flight plan which you have stopped building (which is also the case if you are editing an existing flight plan), whether it is at the start, the end or the middle of the flight plan, you will need to highlight the appropriate point (i.e.: either the start waypoint (S), the end waypoint (E) or the leg line in which you wish to add a new waypoint). As soon as you do this, the ADD WPT or GRAB LINE key will appear. Press the ADD WPT or GRAB LINE key to join the pointer back to the flight plan line and then move it to the new waypoint (NOTE: key 2 reverts to ADD WPT at this point). Once over the new waypoint press ADD WPT to insert it, otherwise press PREV PAGE to cancel this action. Pressing Key 1 PREV PAGE again, returns to the screen entered from, saving any changes made.

If, for example you wanted to add DEAL into the existing flight plan going from MANSTON to DOVER VOR shown in the illustration above, you would first position the pointer over the track line between Manston and Dover VOR, thereby highlighting it and then press Key 2, GRAB LINE. This will pick up the line. You would then move the pointer, stretching the track line like a rubber band, until it was over DEAL and press Key 2, ADD WPT. The new track line would then be set joining MANSTON to DEAL to DOVER VOR and the numbers shown next to DOVER VOR and all subsequent waypoints would be increased by one. DEAL would become 01, DOVER VOR 02 etc.

If, for example you wanted to add HERNE BAY to the end of the flight plan illustrated above, simply move the pointer over MANSTON, thereby highlighting it and then press Key 2, ADD WPT. This will draw a line from Manston to the pointer. Next move the pointer until it is over HERNE BAY, highlight it and press Key 2, ADD WPT again.

To delete a waypoint from a flight plan, point at the item you wish to remove and press Key 5, DELETE WPT. To delete a newly created user waypoint, you have to return to Screen 9, Manual User Waypoint Edit Screen, or 10, View and Edit User Waypoints on the Map Screen. You can create user waypoints on Screen 19 but not delete them from there.

Airways Flight Planning

An airways route can automatically be entered into a flight plan by selecting AIRWAYS from Screen 13 Database Selection screen.

To enter an airways route move the cursor to the AIRWAY field and enter the airway number using the joystick. Next enter the waypoint at which you plan to join the airway and the waypoint at which you wish to leave the airway. The software will only allow you to enter waypoints that are on the airway that you have selected.

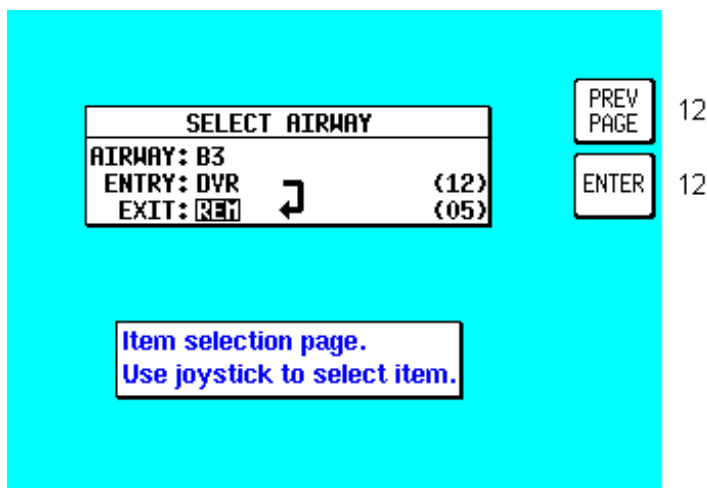

Screen 17: Airway Selection Screen

Pressing Key 1 PREV PAGE will return to Screen 12 Flight Plan Program/Edit Screen, whilst pressing Key 2 ENTER will automatically insert all the waypoints between the select entry and exit points (including the selected entry and exit points) into the flight plan.

If you plan to change airways at a specific waypoint, select AIRWAYS again from screen 13, and enter the new airway designator using the joystick. This time however, set the entry point as being the first waypoint on the new airway AFTER the point at which you join it. This is to avoid having a duplicate waypoint at the changeover.

MAP MODE SCREENS

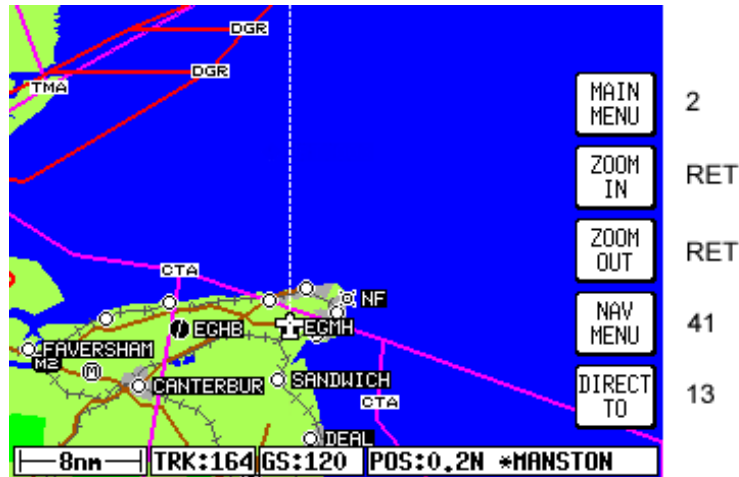

Joystick movement calls screen 39
 Screen 38: Basic Map Mode Screen

Pressing MAP in Main Menu will access this Screen. When you enter this Screen, if the Skymap IIIC's internal GPS receiver has been able to establish a fix or if the external GPS you are using to feed your Tracker IIIC is sending valid data, a Screen similar to the above will be displayed. The map is initially displayed at the Zoom Level where the Scale Bar represents 8nm. This is approximately the same scale as a 1:500,000 chart. If there is no valid GPS fix data available, the words NO FIX POSSIBLE will be shown across the centre of the screen in a box. If the fix is lost at any time during normal operation of the unit, the same NO FIX POSSIBLE box will be overlaid on the map. For an External GPS source the additional messages NO EXTERNAL POSITION DATA and INVALID EXTERNAL POSITION DATA may be displayed in place of NO FIX POSSIBLE.

The map will be shown in either North Up mode or Track Up mode depending upon the setting you have made from Screen 22, Map Customisation Screen. The displayed data will be updated every second. From this page, if you press Key 1, Screen 2 Main Menu will take its place. You can use Keys 2 and 3 at any time to zoom the map in and out to whichever one of the twelve pre-set scales you wish to use. The levels of detail appearing at each zoom level can be selected on Screen 22A/B or C, described in the Setup Screens Section of this Manual. If you want to zoom in or out by more than one step at a time, you can apply multiple presses to Keys 2, ZOOM IN, and 3, ZOOM OUT, whilst watching the scale bar calibration figure and the ZOOMING message box.

The small boxes marked TRK: and GS: display your present track and ground speed. Ground speed is displayed in the units selected on Screen 22, Map Customisation Screen. Track will be magnetic (i.e.: true with local variation automatically taken into account).

The box marked POS: will display your present position as a distance and cardinal bearing from the nearest item in the database. The geographical item used to describe your position to you is chosen on the basis of the POSITION REF: setting on Screen 22, Map Customisation Screen.

If you have chosen VOR's as the position reference on Screen 22, your position will be reported as a distance (range) and bearing from the nearest VOR. If you have chosen VOR's & AIRPORTS as the position reference on Screen 22 and your position is within 5nm of an airport, your position will be reported as a distance and bearing from that airport

even if there is a VOR nearer (i.e. airports have priority). If there is no airport within 5nm then your position will be reported with respect to the nearest VOR or airport.

If you have chosen ALL DATA as the position reference on Screen 22 and your position is within 5nm of an airport, your position will be reported as a distance and bearing from that airport, even if there are nearer VORs, NDBs, towns, VRPs or user waypoints. If there is no airport within 5nm then your position will be reported with respect to the nearest airport, VOR, NDB, VRP, town or user waypoint.

All airport names are shown preceded by an asterisk character (*) in order to distinguish them from towns or cities with similar names, which may have significantly different locations.

At the bottom left hand corner of the display you will also see a Scale Bar showing a measurement. The measurement may be in nautical miles, statute miles or kilometres depending on the map units, which you have selected from Screen 22, Map Customisation Screen.

Pressing Key 4 will take you to Screen 41, the NAV Menu Cover Screen. Pressing Key 5 will take you to Screen 13 from which you can select a DIRECT TO destination.

Under normal circumstances, you will not see any joystick pointer on Screen 38. However, if you do move the joystick, a pointer will appear just beside your present position icon and the display will change to Screen 39 below.

Data Interrogation and Graphical DIRECT TO

DETAILED OPERATION



This screen times-out back to previous screen if joystick not moved or a key is not hit for 30 seconds

Screen 39: Map Mode with Joystick Active Screen

As soon as you move the joystick while in Screen 38, Map Mode, a Screen similar to the above Screen 39 will be displayed. The map freezes in its present position with respect to the joystick pointer and the aircraft symbol indicating your present position starts to move across the Screen. A line appears between present position and the joystick pointer. (The reason the map is made to stop moving is that this makes accurate positioning of the joystick pointer much easier for you.)

Simultaneously, you will see the TRK and GS boxes have now changed to PDIS, PBRG and PETE (where P indicates Pointer). These now show the distance and bearing **from** present position **to** the joystick pointer and the pointer estimated time en-route (PETE).

The PETE is calculated on present GS and would read 00:00 if you were stationary. You can use this function to measure distance, bearing and estimated time en-route to any point on the map. The window formed by the extremities of the Screen can be moved around the map by “bumping” the Screen borders left, right, up or down with the pointer. A PANNING message will be displayed when a border has been bumped in this manner, while the map screen is redrawn. You can still use Keys 2, ZOOM IN, and 3, ZOOM OUT, to zoom the map in and out. When you are finished using this Screen press Key 1, RESET STICK, and the joystick pointer will vanish, your display will return to Screen 38 and the map will be placed back at the aircraft’s present position and at the zoom level it was at prior to activating the joystick. If you don't move the joystick for 30 seconds, this will have the same effect as pressing Key 1.

In addition to finding it useful for measuring distances, bearings and ETE's, you can utilise this Screen for other tasks. If you place the pointer over any data icon and then press Key 4, MORE INFO, Screen 40 (Airport), Screen 40A (Beacon) or Screen 40C (all other data icons) as illustrated below will appear. These Screens contain additional data and information on the selected item.

If you want to navigate directly to any position, press Key 5 and you will obtain a DIRECT TO, taking you to wherever the pointer is positioned, even if it is not pointing to a database item (NOTE: In this case the waypoint will be shown as ‘TEMP WPT’). This is a very useful feature for arbitrary in-flight diversions. After you have pressed Key 5, DIRECT TO, Screen 47, Map Mode with NAV Info, appears, with Key 5 now labelled “DIRECT TO OFF”.

Airport Information

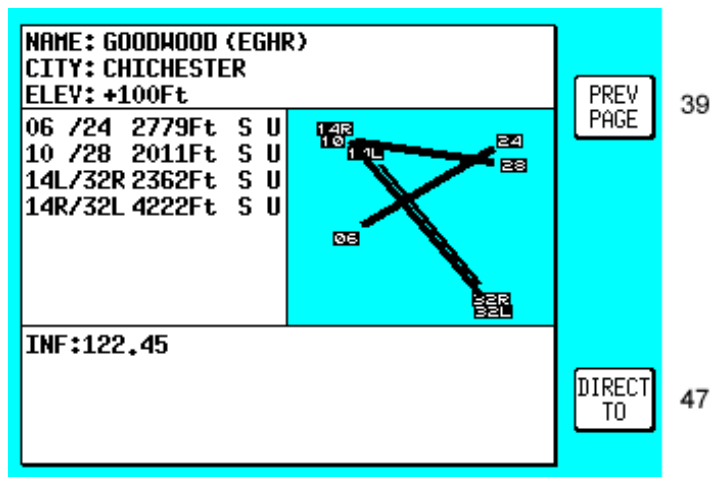

This screen times out back to previous screen after 30 seconds

Screen 40: Map Mode Airport Info Screen

As explained above, you can access this Screen from Screen 39 by placing the joystick pointer over an airport icon and pressing Key 4, MORE INFO. All the information given here is derived from the built-in Jeppesen database. Runway surfaces are shown as an H for hard and an S for soft. Lighting is shown as an L for lit and a U for unlit.

To initiate navigation to the chosen airport all you have to do is press Key 5, labelled DIRECT TO. To return to the Map of Screen 39 you should press Key 1, PREV PAGE. Alternatively, the unit gives you 30 seconds to read what you require from the Info Screen

and then automatically returns to Screen 39.

Pressing Key 5, DIRECT TO, in MAP Mode when the joystick is not active, calls up the Select Database Screen; from here you can select an airport of interest from the airports database as if you were selecting it for a DIRECT TO.

Beacon Information

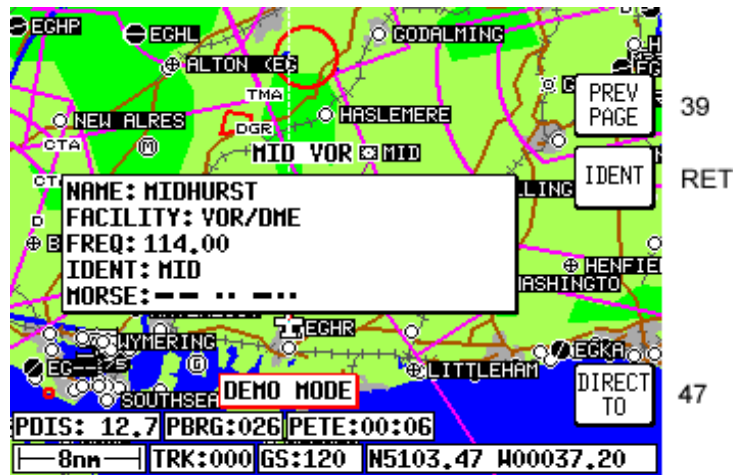

This screen times-out back to the previous screen if joystick not moved or key is not hit for 30 seconds

Screen 40A: Map Mode Beacon Information Screen

As explained above, you can access this Screen from Screen 39 by placing the joystick pointer over a VOR or NDB icon and pressing Key 4, MORE INFO. Full details of the Beacon are listed, type, frequency and ident. The fourth line in the box is a visual representation of the Morse ident and if you are one of those pilots whose knowledge of Morse is less than perfect, all you have to do is press Key 2, IDENT. The unit will then sound the correct ident (on its internal bleeper and on the external alarm, if this is switched on). You can then compare this to the ident you are hearing over the radio to verify that you are indeed tuned to the beacon you want.

To initiate a goto for the chosen Beacon (VOR or NDB) all you have to do is press Key 5, labelled DIRECT TO. To return to the Map of Screen 39 you should press Key 1, PREV PAGE. Alternatively, the unit gives you 30 seconds to read what you require and then automatically returns to Screen 39.

Pressing Key 5, DIRECT TO, in Map Mode when the joystick is not active, can also access this Screen. Allowing you to call up the item of interest from the either the VOR's or NDB's database as if you were selecting it for a DIRECT TO, although if the screen is accessed in this manner the map is not displayed.

General Icon Information

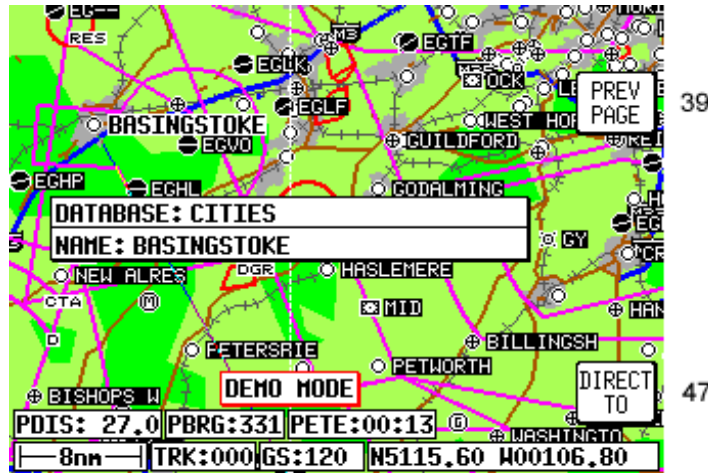

This screen times-out back to previous screen if joystick is not moved or key is not hit for 30 seconds

Screen 40C: Map Mode General Information Screen

As explained above, you can access this Screen from Screen 39 by placing the joystick pointer over any data icon that is not an airport, VOR or NDB and pressing Key 4, MORE INFO. All available information concerning the chosen data item is then listed.

To initiate a goto for the chosen item all you have to do is press Key 5, labelled DIRECT TO. To return to the Map of Screen 39 you should press Key 1, PREV PAGE. Alternatively, the unit gives you 30 seconds to read what you require and then automatically returns to Screen 39.

Airspace Interrogation

In order to interrogate a piece of airspace in MAP Mode, move the joystick operated pointer and point at one of the airspace boundaries. After you have released the joystick, the software will search the airspace database and after a short time will re-draw the piece of airspace to which you have pointed in a bolder line. **IMPORTANT:** When a single airspace boundary line is shared by two different pieces of airspace (which is very common), the airspace with the **lower** vertical limit will always be highlighted.

Once you are sure the piece of airspace highlighted is the piece you want information on (you may have to zoom out to verify this, but beware, some airspace switches off as you zoom out dependant on the settings made in Screen 22C, Airspace Data Class Setup Screen), press MORE INFO key and Screen 40B, Airspace Information Screen, will be displayed.

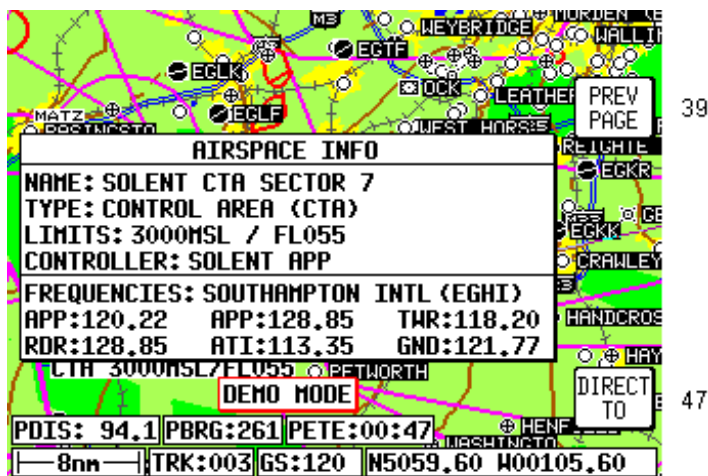

This screen times out back to previous screen if joystick is not moved or key is not hit for 30 seconds

Screen 40B: Airspace Information Screen

The information shown on this screen is all the information from the internal Jeppesen database that is relevant to the airspace you have selected. If some of the fields are blank or say SEE CHART, this means that Jeppesen data is not available for that particular item.

NAV MENU SCREENS

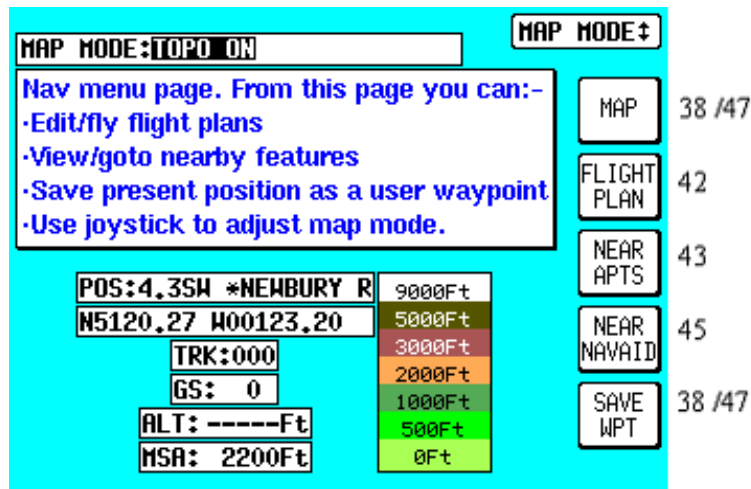

Screen 41: NAV Menu Cover Screen

You can enter this important Screen by pressing Key 4, NAV MENU, while in MAP Mode (on Screen 38 or 47). It is a versatile Screen with several useful functions.

If you move the joystick up or down when in this Screen, the screen layout presented when in Map Mode with NAV Information (or NAV Mode i.e. flying a flight plan or a DIRECT TO) can be selected to be one of the following

TOPO ON: Large map, full colour cartography, and small NAV information text.

TOPO ON, LRG TXT: Large map, full colour cartography, and large NAV information text. This will revert to the TOPO ON large map when the joystick is hit.

TOPO ON, CDI: Pseudo CDI style display, which reverts to TOPO ON large map when joystick is hit. The TOPO ON map is also displayed if no flight plan or DIRECT TO is active.

TOPO OFF: Large map, black background, no cartography, and Jeppesen data only, small NAV information text.

TOPO OFF, LRG TXT: Large map, black background, no cartography, and Jeppesen data only, large NAV information text. This will revert to the TOPO OFF large map when the joystick is hit.

TOPO OFF, CDI: Pseudo CDI style display, which reverts to TOPO OFF large map when joystick is hit. The TOPO OFF map is also displayed if no flight plan or DIRECT TO is active.

Please refer to the Map Setup Screens in the Setup Screens Section of this Manual for further information regarding data settings for each mode.

If you wish to return to your previous Map Mode Screen at any time, press Key 1, MAP.

Key 2, FLIGHT PLAN, gives you direct access to Flight Planning Mode where you can manually select, cancel and edit flight plans as required.

If you press Key 3, NEAR APTS, you will be presented with Screen 43, Ten Nearest Airports Screen, on which you can read off the ten airports nearest to your present

position.

If you press Key 4, NEAR NAVAID, you will see Screen 45, Ten Nearest Beacons Screen, giving you details of the ten VOR's and NDB's nearest to you. For more information on Screens 43 and 45 refer to the Ten Nearest later on in this Section of the Manual. When a DIRECT TO is active, Key 4 will read CENTER CDI which centres the Course Deviation Indicator in the bottom right hand corner of the display. The NEAR NAVAID function will still be available via the NEAR APTS function.

If you wish to save your present position, press Key 5, SAVE WPT, and your co-ordinates will be saved as the next available user waypoint number. Once the user waypoint has been saved, the Screen will revert to Map Mode (Screen 38 or 47) where the new user waypoint will already feature on the map.

The text boxes in the bottom half of the screen gives the following information:

NAV Mode selected (one of six options described above)

Position in plain English

Position in **latitude/longitude** (or the co-ordinate system selected on the Map Setup Screen)

Track and **Ground Speed**

GPS Altitude

MSA for the present position

The MSA box displays the highest Grid MORA value within a ten mile radius of your present position at all times. See APPENDIX C for a more detailed explanation of Grid MORA.

WARNING: The MSA altitudes displayed are advisory in nature only. They should not be relied upon as the sole source of obstacle and terrain avoidance information. Always refer to current aeronautical charts for appropriate minimum clearance altitudes.

Selecting a Flight Plan

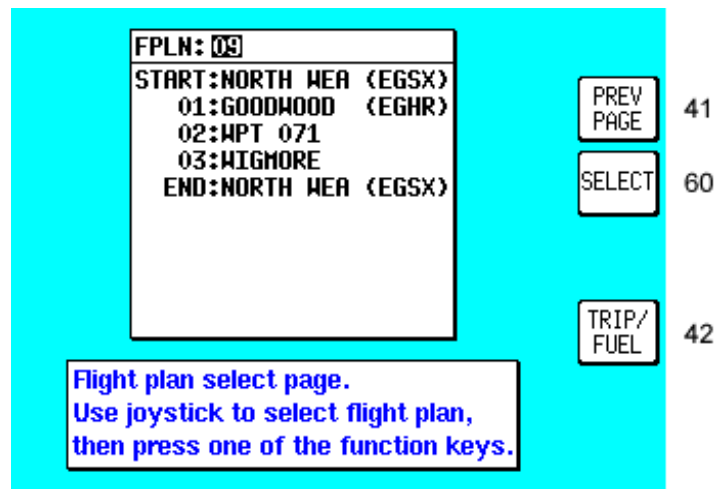

Screen 42: Flight Plan Selection Screen

Pressing Key 2, FLIGHT PLAN, on Screen 41, NAV Menu Cover Screen, enters this Screen. On entry to this Screen you will see a cursor positioned over Flight Plan Number 01, or if there is a flight plan already active, its number will be shown instead of the Flight plan last touched. You will see the first few items of the selected flight plan together with its final destination in the box under the Flight Plan Number. You can select any flight plan you want by using the joystick to scroll the flight plan number up or down. You are free to select any one of the 99 available flight plans. If you wish to return to the NAV Menu Cover Screen (Screen 41) press the PREV PAGE Key 1.

If the selected flight plan is already running, Key 5 will read FPLN OFF. If there is no active flight plan, Key 5 will be blank and Key 2 will read SELECT. Pressing Key 2 will call Screen 12, Flight Plan Program/Edit Screen for the selected flight plan. An active flight plan can be switched off at any time by pressing Key 5, FPLN OFF.

Pressing Key 5 will cancel the active flight plan and allow you to gain access to what was the active flight plan. (In the interests of safety, the software has been designed not to permit you to edit and fly a flight plan at the same time.)

Pressing Key 4 gives a shortcut to Screen 60, the E6-B Trip/Fuel Planning Screen (see Trip/Fuel Planning in the E6B Calculator Section of this Manual for more detail). Whenever Screen 60 is displayed the flight plan selected on Screen 42 will automatically be shown.

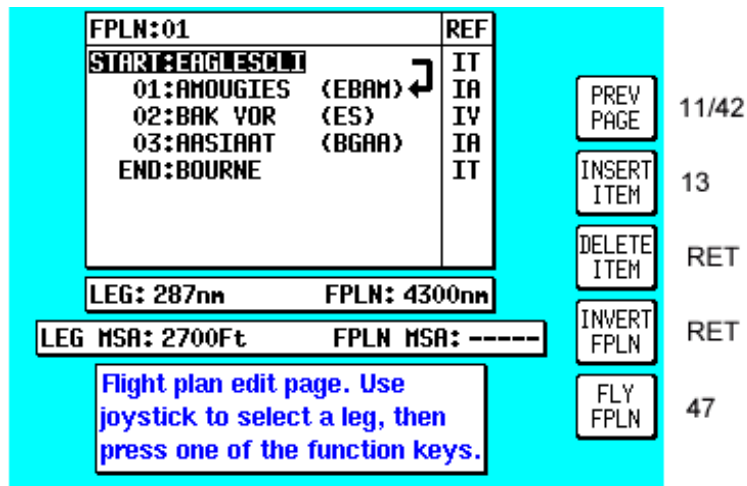

Screen 12: Flight Plan Program/Edit Screen

In order to select a flight plan to fly, bring up the desired Flight plan Number with the joystick and press Key 2, SELECT, in Screen 42, Flight Plan Selection Screen. This will call Screen 12 from which you can choose to edit the flight plan, reverse the flight plan or activate the flight plan. In order to activate the flight plan, simply use the joystick to select the desired leg then press Key 5, FLY FPLN. If you have highlighted a leg other than Start or 01 you will be prompted with the following message, "Do you want to fly the first leg of the flight plan or the currently selected leg?" Three possible responses are available, Key 1, ABORT will cancel the fly flight plan action, key 3 FIRST LEG to fly from the first leg, or key 5 SEL'D LEG to fly from the highlighted leg.

NOTE: If you have activated AUTO LEG SELECT on Screen 23, NAV Mode Customisation Screen, the nearest leg to your present position will automatically be selected for you as soon as you enter Screen 12.

Ten Nearest Airports

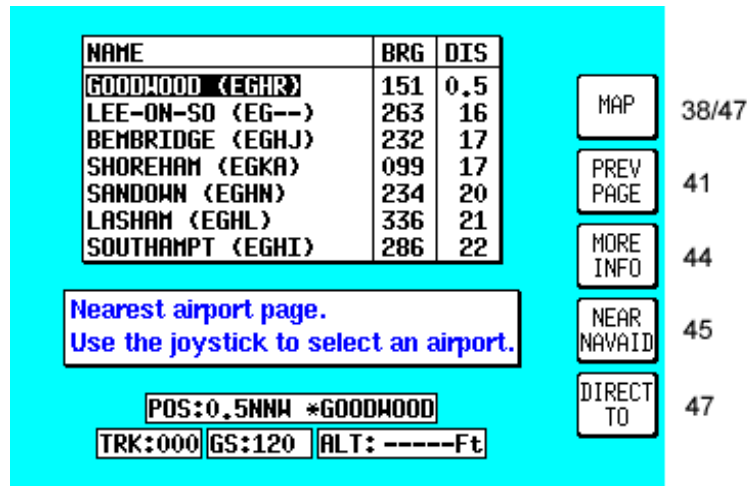

Screen 43: Ten Nearest Airports Screen

This Screen is accessed by pressing Key 3, NEAR APTS, on Screen 41, NAV Menu Cover Screen, and dynamically shows the range and bearing of the ten nearest airports. When this Screen appears you will find a cursor over the first airport in the list.

You can scroll up and down the list by using the joystick. Once the cursor is lying over the name of the airport you require, if you press Key 3, MORE INFO, Screen 44 below will appear, giving you additional information about that airport.

To obtain a DIRECT TO for the chosen airport all you have to do is press Key 5, labelled DIRECT TO, and you will switch back to (Screen 47) MAP mode with the selected DIRECT TO activated.

Key 1, MAP, returns you to MAP Mode, Screen 38 or 47. Key 2 returns you to the NAV Menu Cover Screen (Screen 41). By pressing Key 4, NEAR NAVAID, you can switch to Screen 45, Ten Nearest Beacons, giving information about the ten nearest beacons.

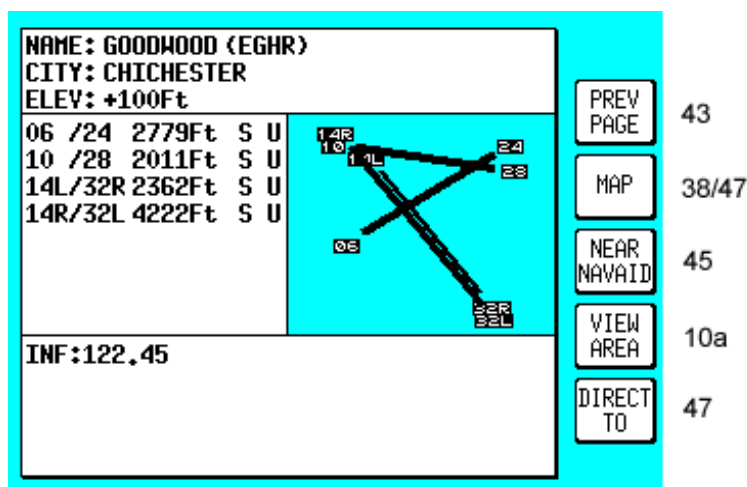

Screen 44: Airport Information Screen

Once you have selected an airport on Screen 43 and pressed Key 3, MORE INFO, the display will change to Screen 44 above. This gives additional information about runways, frequencies, elevation etc. for the airport in question.

To return from this Screen to Map Mode (Screen 38 or 47) you simply press Key 2. To select another airport from the Ten Nearest (Screen 43) you press Key 1 and if you want to see the list of ten nearest beacons, simply press Key 3, which will take you directly to Screen 45, Ten Nearest Beacons. To obtain a DIRECT TO for the chosen airport all you have to do is press Key 5, labelled DIRECT TO, and you will switch back to (Screen 47) MAP Mode with the selected DIRECT TO activated.

If you want to view the area immediately around the chosen airport, press Key 4. This will call Screen 10A which is very similar to Screen 10, the View and Edit User Waypoint on the Map Screen. Screen 10A can be cancelled by pressing Key 1, PREV PAGE.

Beacons

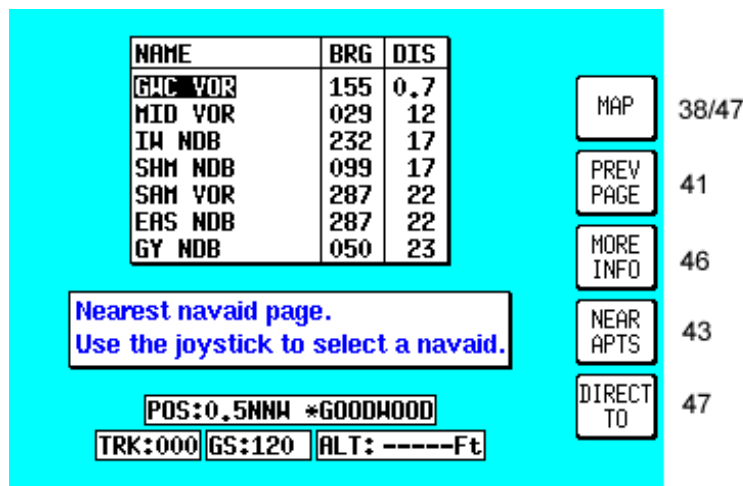

Screen 45: Ten Nearest Beacons Screen

This Screen is accessed by pressing Key 4, NEAR NAVAID, on Screen 41, NAV Menu Cover Screen, and dynamically shows the range and bearing of the ten nearest beacons. When this Screen appears you will find a cursor placed over the first beacon in the list. The list can be scrolled up and down using the joystick. Once you have placed the cursor over the name of the beacon you want, press Key 3, MORE INFO, to display Screen 46 below, which gives additional information about that beacon.

Pressing Key 1 will return you to MAP mode (Screen 38 or 47). Key 2 returns you to Screen 41, NAV Menu Cover Screen. Pressing Key 4, NEAR APTS, will take you to Screen 43, giving you the list of the ten nearest airports.

To obtain a DIRECT TO for the chosen beacon all you have to do is press Key 5, labelled DIRECT TO, and you will switch back to (Screen 47) MAP mode with the selected DIRECT TO activated.

DETAILED OPERATION

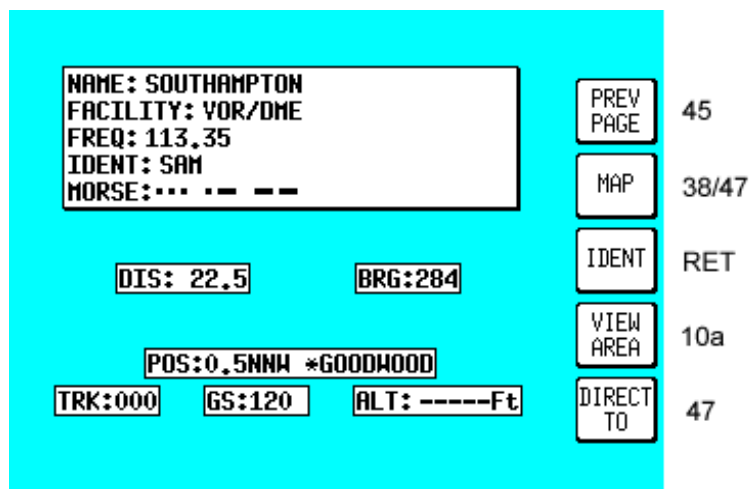

Screen 46: Beacon Information Screen

The Screen above shows the additional information about the beacon chosen on Screen 45, Ten Nearest Beacons.

From here by pressing Key 2 you will get back to MAP mode (Screen 38 or 47). To select another beacon from the Ten Nearest (Screen 45) you press Key 1. If you press Key 3, IDENT, the unit will mimic the Morse code ident for the chosen beacon on the internal beeper (and on the external alarm if you switched this on in Screen 23, NAV Mode Customisation Screen).

If you want to view the area immediately around the chosen beacon, press Key 4. This will call Screen 10A which is very similar to screen 10, the View and Edit User Waypoint on the Map Screen. Screen 10A can be cancelled by pressing Key 1, PREV PAGE.

To obtain a DIRECT TO for the chosen beacon all you have to do is press Key 5, labelled DIRECT TO, and you will switch back to (Screen 47) MAP mode with the selected DIRECT TO activated.

MAP MODE WITH NAV INFORMATION

Whenever a flight plan is active or you have called for a DIRECT TO, the map will have extra navigation information added to it and will resemble Screen 47 below. Alternatively you may have selected one of the other Navigation Modes detailed in the NAV Menu Screens Section of this Manual. The same navigation data is presented on all the alternative screens in different ways. The following text refers to the standard Navigation Mode Screen setting (TOPO ON). Alternative Screens 47A and 47B are discussed at the end of this section.



Joystick movement calls screen 39.

Screen 47: Map Mode with NAV Information Screen

If the TOPO OFF Large Map Mode is selected, the map will display aeronautical data only on a black background.

The Course Deviation Indicator (CDI) at the bottom right of the map can be switched ON or OFF or be set to work numerically and the Full Scale Deflection (FSD) selected on Screen 23, NAV Mode Customisation Screen. If you have selected the CDI alarm ON, when the last element of the CDI bar graph comes on (or when the full scale value as set on Screen 23 is reached) the internal and external alarms (if switched on) will beep at a rate of 2Hz for 5 seconds.

Key 5 will change to ALARM OFF and if you press this before the 5 seconds are up this will silence the alarm. When the alarm switches off automatically after 5 seconds, Key 5's label will go blank and have no function for 2 seconds then revert to DIRECT TO (or DIRECT TO OFF). This is to make sure you don't inadvertently select or cancel DIRECT TO mode if you press this Key just as the alarm is cancelling automatically. The CDI alarm resets itself as soon as you come back within the full scale set. It will then be reactivated whenever the full scale is reached again.

The box at the bottom left of the map window shows the destination point when you are in DIRECT TO Mode preceded by the "DIRECT TO" symbol or the FROM and TO waypoints when you are in Flight Plan Mode.

A great deal of other navigation information is available to you above and below the map. (The positioning of this data that is described in the following relates to when the screen is in Landscape Mode. The position of some of the items is different when Portrait Mode is used.) Starting at the top of the screen on the left hand side you will see DIS. This is the distance or range to run to the destination point from your present position. This distance

figure is given in whichever units you selected on Screen 22, Map Customisation Screen. In the left centre of the screen at the top you can read BRG. This is the magnetic bearing to the next turning point.

To the right of BRG at the top of the map is the ETE. This gives the Estimated Time En-route (i.e. the estimated time, in hours and minutes, that it will take you to get to the destination point from your present position assuming you maintain your present ground speed).

On the Skymap IIIC unit only, at the top right of the map is the ETA. This is the Estimated Time of Arrival at the next turning point. **Ensure you have set the local time offset correctly to get local ETA's.** Refer to the GPS Status Screens Section of this Manual for more details. (The reason that ETA is not available on Tracker IIIC is that, depending on the type of GPS receiver in use, real time and local time offset is not always known.)

In the left centre of the screen at the bottom is TRK. This is the actual magnetic track the aircraft is travelling over the ground. By comparing this with your magnetic heading you can make an estimate of the crosswind component.

To the right of TRK is GS. This is the actual ground speed of the aircraft and is displayed in Knots if you set the map units to nautical miles on Screen 22, Map Customisation Screen, MPH if you set them to statute miles or KPH if the map units are set to kilometres. By comparing the GS with your TAS you can make an estimate of the head or tail wind component. Alternatively refer to Screen 58, Density Altitude, True Air Speed, and Winds Aloft in the E6B Calculator Screens section of this manual.

If ground speed is less than 3 Kt., the map will revert to North Up even if Track Up is selected. This is to stop the map rotating when static due to the small position fix changes caused by atmospheric and other effects.

If you have entered this Screen 47 by activating a flight plan, a DIRECT TO can be performed on top of the flight plan. You can initiate the DIRECT TO either to an item from the database or by using the joystick pointer or by calling up one of the 10 nearest airports or beacons. In each case the Key 5 label will change to "DIRECT TO OFF". The flight plan that previously was active will fall into the background and will be replaced by the DIRECT TO information. When the DIRECT TO destination is reached or whenever you press the DIRECT TO OFF Key (Key 5), the flight plan and its information will be reinstated.

Viewing En-route ETA's and Direct-To Page

When flying a flight plan, the ETA's for each leg of the flight plan can be viewed on Screen 41A which is accessed by pressing Key 5, DIRECT TO on the MAP mode screen (screen 47).

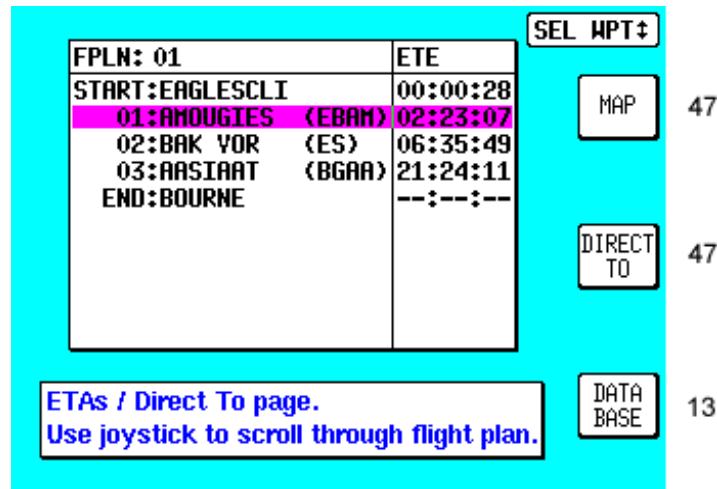

Screen 41A: View ETA's and Skip Leg Screen.

On entry to Screen 41A, a magenta cursor will be placed over the current destination waypoint.

Direct To

The Direct To function allows you to perform a short cut whilst flying a flight plan by skipping over intermediate legs and flying directly to a point further along your planned flight plan. Once the selected point is reached, the normal flight plan is automatically resumed.

A black cursor bar is hidden behind the magenta bar that is highlighting the current destination waypoint. The black cursor is used to select the point to go Direct To. This cursor can be moved up and down the active flight plan with the joystick.

If a waypoint further down the flight plan is selected then the DIRECT TO key is hit, the unit will return to the map with a pseudo DIRECT TO running on top of the flight plan to the selected point. The CDI will be centred and the FROM-TO box will be replaced with a direct to box. Once the selected point is reached, the normal flight plan is automatically resumed.

This function is very useful if you have been forced off your planned flight plan and wish to take the flight plan up again at a later turning point. Note that although this is now a direct routing, it is still to a flight-planned waypoint and therefore the DIRECT TO OFF key is not shown. To revert to your original flight planned route you can either select DIRECT TO your original next waypoint or reactivate the flight plan from screen 12.

Arrival at an En-route User Waypoint



Joystick movement calls screen 39
 Screen 48: NAV Information and WPT ALERT Flags Showing – En-route Screen

To set the radius for the Arrival Alarm you should refer to the data on Screen 23, NAV Mode Customisation Screen. When the distance remaining to run to an en-route waypoint falls below the Arrival Alarm value, the [WPT ALERT] flag is displayed and the internal and external alarms (if switched on) beep at a rate of 2Hz for 5 seconds. To make the change to NEXT LEG you have to press Key 1 and if you wish to silence the alarm before the 5 seconds are up, simply press Key 5, the label of which has changed to ALARM OFF. The alarm is switched off automatically after 5 seconds; Key 5 will go blank and have no function for 2 seconds. It will then revert to DIRECT TO. This is a safety measure to prevent you from inadvertently selecting DIRECT TO mode by pressing Key 5 just as it is cancelling automatically.

Once you have pressed Key 1 to select the next leg, Screen 47 re-appears showing all the relevant information for the new leg. The next leg of the flight plan will now be displayed as a solid magenta coloured line with a black border. This black border differentiates the track line from controlled airspace which has no border.

If you pass the waypoint the flag will change to [WPT PASSED]. If the unit has been set up for AUTO NEXT LEG in Screen 23, then as the waypoint is passed the unit will automatically revert to Screen 47 with all the new leg information. Key 1 will go blank and inactive for two seconds. It will then revert to MAIN MENU.

When the WPT Alert alarm has been given, a new box will appear at the bottom of the screen showing the new course [NEW CRS XXX] to steer for the next leg of the flight plan. The next leg of the flight plan will also be displayed as a solid white line.

Prior to reaching a waypoint within a flight plan, Turn Anticipation provides navigation along a curved path segment to ensure a smooth transition between two adjacent legs in the flight plan. The curved path segment is based upon the aircraft's groundspeed and the amount of course angle change between the legs.

Turn Anticipation will only work if it is selected ON in Screen 23, NAV Mode Customisation Screen, and if the course change is greater than 5° and less than 90°. If the course change is less than 5° then turn anticipation is not necessary. If the course change is greater than 90° it is up to the pilot which way round the turning point he turns.

If Turn Anticipation is set to ON and the upcoming leg satisfies the Turn Anticipation rules (i.e. course change greater than 5° or less than 90°), the Turn Anticipation function is activated. If Turn Anticipation is switched OFF or the upcoming leg course change is greater 90°, you may get a STEEP TURN warning. The Steep Turn warning will be given if the upcoming turn will involve a bank angle in excess of 25° based on current ground speed.

Arrival at Your Final Destination



Joystick movement calls screen 39

Screen 49: NAV Information and WPT ALERT Flags Showing - Final Screen

This Screen appears whenever the next waypoint is the last in the current flight plan. When the distance to run to the last WPT falls below the Arrival Alarm value, the [WPT ALERT] flag is shown and the internal and external alarms (if switched on) beep at a rate of 2Hz for 5 seconds.

The label for Key 1 changes to NAV OFF and that for Key 5 changes to ALARM OFF. If you press Key 5 the audible alarm is silenced. The alarm will switch itself off automatically after 5 seconds, then after a further 2 seconds the label for Key 5 will revert to DIRECT TO (or DIRECT TO OFF if in DIRECT TO mode).

If you are in Flight plan Mode when Key 1 is pressed, the Navigation MAP Mode is cancelled and Screen 38 is called. If you are in DIRECT TO mode when Key 5 is pressed, DIRECT TO Mode is cancelled and Screen 38 will appear. If you are in DIRECT TO Mode with an underlying flight plan still active when you press Key 5, DIRECT TO Mode will be cancelled and Screen 47 will reappear with the original flight plan reinstated.

As the last waypoint is passed, the flag will change to [WPT PASSED].

Alternative Navigation Map Modes

You may have selected one of the other Map presentation modes detailed in the NAV Menu Screens Section of this Manual. The same navigation data as described previously is presented on all the alternative screens in different ways.

TOPO ON / TOPO OFF Large Text Mode

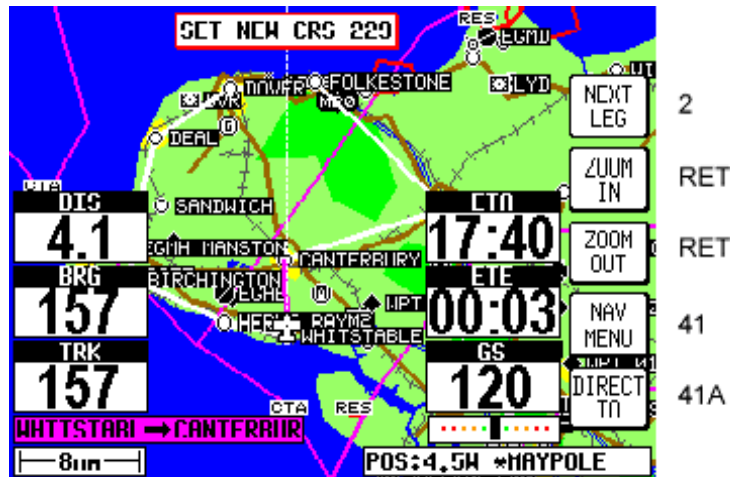

Screen 47A: TOPO ON Large Text NAV Information Screen.

This Screen presents the numeric navigation information in large text laid over the map display in such a way as to allow you a forward view of the map if being used in Track Up Mode. As with standard Map NAV Mode, the CDI scale and format may be adjusted. If the joystick is touched, the display will immediately revert to Map format to allow full use of map graphics. When the joystick is reset or after 30 seconds with no key or joystick activity, Screen 47A will be reinstated.

As with standard Map Mode, if the TOPO OFF Large Text Mode is selected, the map will display aeronautical data only on a black background.

TOPO ON / TOPO OFF CDI (Pseudo CDI) Mode:

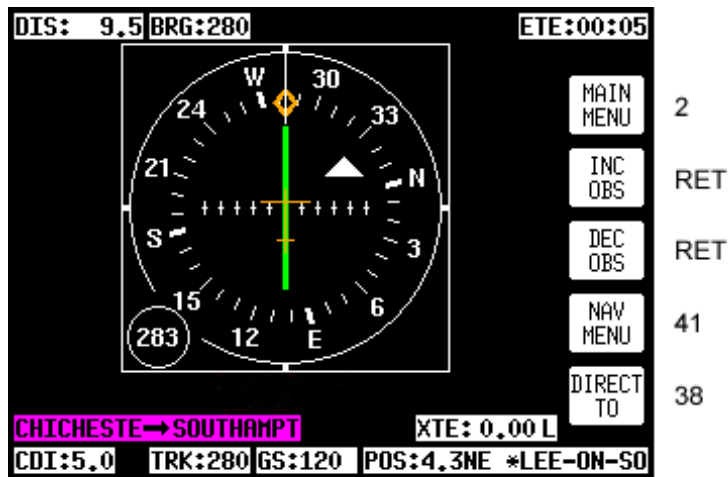

Screen 47B: CDI NAV Information Screen

This Screen presents numeric navigation information in small text but instead of a map display, shows a pseudo CDI complete with OBS knob. The aircraft icon in the center of the CDI will remain static and the outer ring represents the desired magnetic track between the start waypoint and the destination waypoint (i.e. magnetic bearing to waypoint if you were on track). On entering NAV Mode or activating a new flight plan leg or a DIRECT TO, the outer ring will show the desired track to the active waypoint.

A GPS TRACK bug, which rotates with the aircraft's actual track, is positioned on the CDI outer ring. This indicates the actual magnetic track of the aircraft. There is also included a conventional TO / FROM flag.

Flying with the pseudo CDI is very similar to flying with a conventional VOR indicator. Off track error (XTE) is represented by a bar that moves left or right of center. The center of the scale represents the aircraft's position. As with a conventional CDI or VOR indicator, to correct your track error, fly towards the bar. The full scale deflection or scale of the CDI can be selected on Screen 23, NAV Mode Customization Screen.

In order to gain, and remain on the desired track, adjust your aircraft heading until the CDI bar is centered. Once the CDI bar is in the center of the display indicating no cross track error (XTE), adjust your aircraft heading in small increments until the track bug, which rotates around the outer ring, is at the top of the display.

Once the CDI is centered and the track bug is aligned at the top of the display you are flying precisely along your desired track. If the track bug is aligned at the top of the display but the CDI bar is not centered, this indicates you are flying parallel to your desired track by however far the XTE is indicating.

If whilst flying a flight plan you need skip to another waypoint in the flight plan, press key 5 (DIRECT TO) followed by key 3 (DIRECT TO) in exactly the same way as described earlier in this section.

The TO / FROM flag will normally point up to indicate you are flying TO the waypoint. When you pass your destination waypoint, the TO / FROM flag will point down to indicate you have passed the waypoint and you are now flying away FROM your destination. As you pass your waypoint and the FROM flag appears, the desired track ring will remain fixed at the original desired track and the CDI will continue to show track error left or right of the extended leg line.

If whilst en-route to a destination you decide that you would like to approach that destination point from an angle other than that displayed on the CDI by the desired track ring, you can alter the desired track setting by pushing the INC OBS (increment OBS) or DEC OBS (decrement OBS) Keys.

This has the effect of rotating your desired track ring and hence rotating the desired track line on the map screen using the destination point as a pivot. For example if you were approaching an airport from the south west on an inbound heading of 070° but the runway in use at that airport was 09, it may be desirable to approach the airport on a heading of 090° so that you were lined up for the approach.

By pressing the INC OBS Key you would increment the desired track setting from 070° to 090°. The CDI would then show a fly left indication because you would be off track to the right from your new track line. By turning left it would then be possible to intercept the new track line then fly straight into the airport on the new approach heading.

If the joystick is touched, the display will immediately revert to Map format (either small or large text as selected) to allow full use of map graphics. When the joystick is reset, Screen 47B will be reinstated. When flying with the CDI selected, WPT ALERT messages and other warnings will be displayed in the CDI area.

In this mode, the small CDI window will show the numeric cross track error, unless it has been selected to OFF in Screen 23 NAV Mode Customisation Screen.

DEMO MODE

To allow you to practice all aspects of navigation on the ground and to become familiar with handling it, your unit can be used as a simulator by selecting its fully functioning Demo Mode. Using this mode you can also replay your logged flight data.

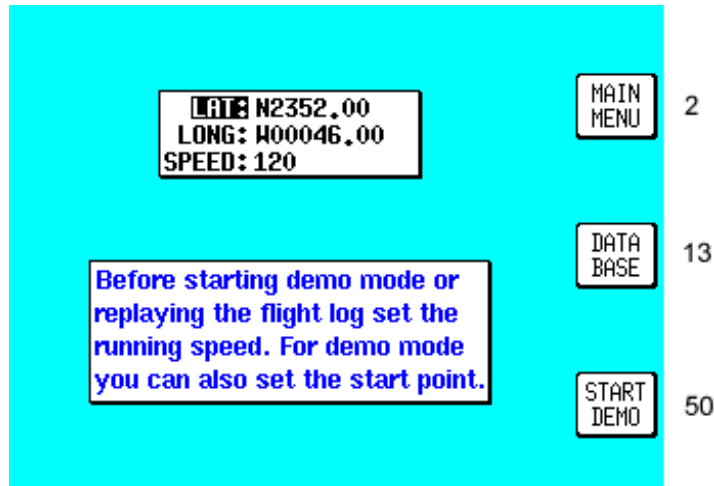

Screen 20: Demo Mode Setup Screen

This Demo Mode Screen can be accessed by pressing Key 3, DEMO MODE, on Screen 1, Title Screen, provided that, since the time you switched it on, your Skymap IIC has not received valid satellite information from its internal GPS receiver, or your Tracker IIC similarly lacks fix data from its external position source.

When you enter Demo Mode you will find a cursor over the word LAT. You can then use the joystick to set up the latitude and longitude for any point from which you want the demo to start. (The default latitude and longitude will be the co-ordinates of your last fix position.) Alternatively you can press Key 3 and select a start point from the built-in database. You can also set the airspeed at which you want to fly the demo to anything between 000 and 999 Knots.

Once you have set your position and speed, if you press Key 5 you will find Screen 38, Map Mode, displayed and you are ready to start Demo Mode. All map Screens that you access whilst Demo Mode is switched on will, for safety reasons, have a DEMO MODE warning box displayed to ensure you do not use them while in the air.

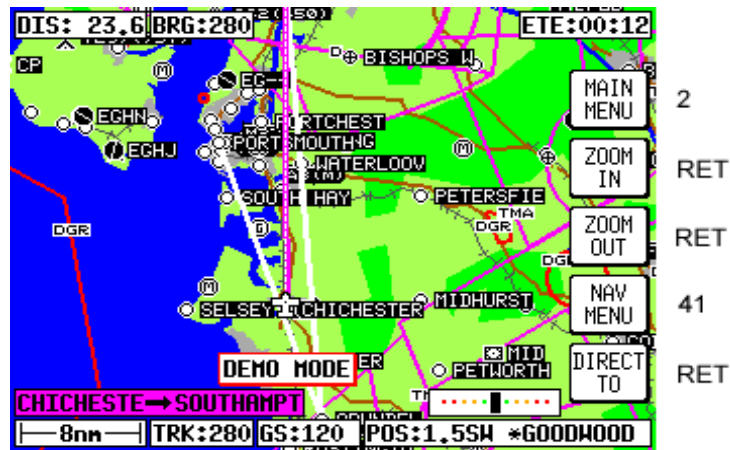

Joystick movement calls screen 39

Screen 50: Representation of Screen 47 Showing DEMO MODE Flag

If you wish to replay the flight data logged into your unit, set the airspeed as explained above then press Key 4. Screen 50 will then be displayed with the logged data being replayed at the specified speed. This allows long flight plans to be replayed in fast motion.

If Demo Mode is active and you switch to Screen 2, Main Menu Screen, you will see Key 3 is now labelled DEMO OFF and can be used to cancel Demo Mode.

E6-B CALCULATOR

E6-B functions are accessible by pressing Key 3, NOTE PAD, in Main Menu followed by Key 3, E6-B CALC, in the Note Pad Screen. This gives access to Screen 57, E6-B Calculator Screen. This function is not available in Demo Mode.

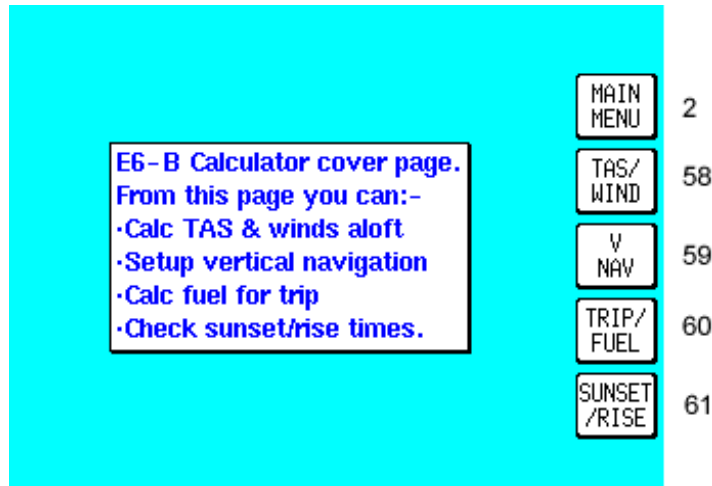

Screen 57: E6-B Calculator Cover Screen

- Key 1 returns you to Screen 2 Main Menu.
- Key 6 calls Screen 58, the Density Altitude/TAS/Winds Aloft Calculator page.
- Key 7 calls Screen 59, Vertical Navigation page.
- Key 8 calls Screen 60, Trip/Fuel Planning page.
- Key 9 calls Screen 61, Sunset/Sunrise Calculator page.

Density Altitude/TAS/Winds Aloft Calculator

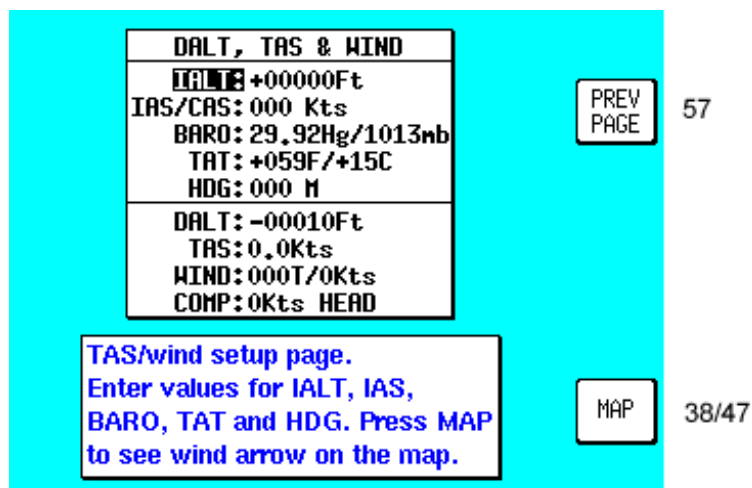

Screen 58: Density Altitude, True Air Speed & Winds Aloft Screen

On entry to this Screen a cursor will be positioned over the Indicated Altitude (IALT) data entry field.

To calculate Density Altitude (DALT) and True Airspeed (TAS) follow these steps.

1. Enter the indicated altitude reading from your altimeter next to the IALT heading. Default value on entry to Screen is GPS altitude for Skymap IIIC or 2000 feet for Tracker IIIC if no altitude value is being received from the position source.
7. Move the cursor over the entry field next to the heading IAS/CAS and enter your indicated or calibrated airspeed. Default value on entry to this screen is GPS ground speed.
8. Move the cursor over the entry field next to the heading BARO and enter the atmospheric pressure in either inches of mercury (Hg) or millibars (mb). Default value is 29.92Hg / 1013mb.
9. Move the cursor over the entry field next to the heading TAT and enter the total air temperature read from your **external** aircraft thermometer in either F or C. Default value on entry to this Screen is 59F/15C.

The calculated density altitude (DALT) and true airspeed (TAS) will now be correctly displayed in the lower half of the Screen.

To calculate Winds Aloft (WIND) and Headwind / Tailwind Component (COMP), follow these steps.

1. Ensure you have followed steps one to four above so that TAS has been correctly calculated.
10. Move the cursor over the entry field next to the word HDG and enter the magnetic heading of the aircraft from your compass or DI. Default value on entry to this Screen is GPS track
11. The wind direction and speed (WIND) along with the head or tailwind component (COMP) will now be displayed in the lower half of the Screen.

When the wind has been calculated and you return to the map Screen by pressing Key 5, MAP, a wind arrow will be displayed on screen, correctly orientated and pointing at the aircraft icon to give a visual representation of the wind direction with respect to the aircraft. The wind arrow will disappear after 30 seconds.

Vertical Navigation (VNAV)

VNAV is a function that tells the pilot when to start descending or climbing in order to reach a certain altitude at a certain distance from the next waypoint and is entered by pressing Key 3, VNAV, on Screen 57, E6-B Calculator Cover Screen.

This function can only be switched on when a Flight plan is being flown or a DIRECT TO is being executed, in other words, when there is a valid destination waypoint.

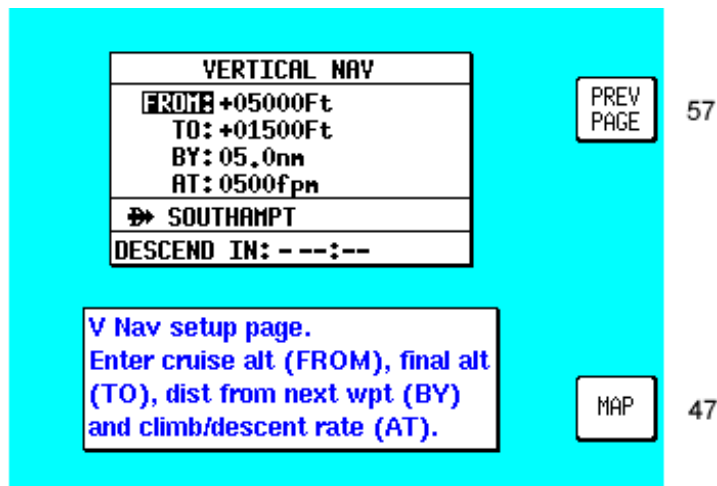
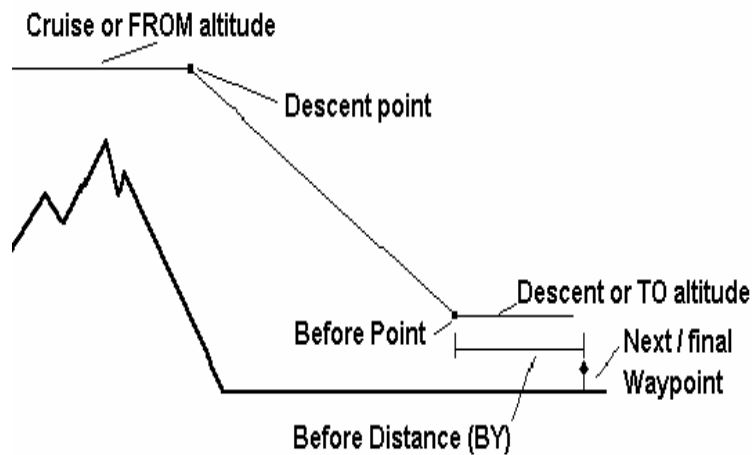

Screen 59: V NAV Setup Screen

On entry to Screen 59, if there is no active waypoint the DESTINATION box will read NO WPT. You must have an active waypoint in order to activate VNAV Mode. If there is an active waypoint its name will be shown.

Once in the VNAV Screen you must enter the cruise altitude (the altitude **FROM** which you will descend), the final altitude (the altitude **TO** which you want to descend), the rate of descent (in FPM feet per minute) and the distance before the upcoming waypoint that you want to achieve the new level BY.

On entry to this Screen, the FROM value will default to GPS altitude if your unit is a Skymap IIIC or to 5000 feet if your unit is a Tracker IIIC (or the last set value). The TO value will default to 1500 feet (or the last set value). The BY value will default to 5.0nm (or last set value) and the AT value will default to 500fpm (or last set value).

The DESCEND IN box will show an active countdown of the time left before you should start your descent and will be recalculated if you change any of the four variables (FROM, TO, BY, AT) or your groundspeed.

If Screen 59 is entered then exited by pressing Key 1, VNAV mode is not activated; the values are simply retained for use later in the flight.

If Screen 59 is entered then exited by pressing Key 5, Screen 47, 47A or 47B (NAV Mode)

Screen will be displayed with the following changes.

1. Key 5 will now read VNAV OFF and there is a new VNAV message box.
12. If the DESCEND IN counter is greater than 00:00, the new message box will show DESCEND IN with the counter value.
13. When the DESCEND IN counter reaches 00:00, the alarm will sound and a message will be displayed across the Screen saying START DESCENT NOW. Key 5 will change to ALARM OFF then back to VNAV OFF. Once Key 5 is hit or the alarm times out, the START DESCENT message will disappear and the VNAV message box will now show ADVISORY ALT: XXXXX ft and count down. The descent angle will be fixed at this point to prevent changes in ground speed from altering the descent profile.

When the advisory altitude is within 500 feet of the TO altitude, the alarm will sound again and a message will be displayed across the Screen saying FINAL ALT IMMINENT. Key 5 will change to ALARM OFF then back to VNAV OFF. Once Key 5 is hit or the alarm times out, the advisory altitude will continue to count down until it reaches the TO altitude. VNAV mode will then cancel automatically.

If you wish to perform a DIRECT TO or select a new flight plan the VNAV Mode will need to be cancelled.

VNAV can be used for climbing as well as descending. If the FROM altitude is set to a lower value than the TO altitude then everywhere the words DESCENT and DESCEND appear, the word CLIMB will be used instead.

Trip/Fuel Planning

This feature is entered by pressing Key 4, TRIP/FUEL, on Screen 57, E6-B Calculator Cover Screen, and allows you to call up any flight plan and view the following details about each leg of the flight plan. This feature can also be entered whilst flight plan planning from Screens 11 or 42, Flight Plan Selection Screens.

1. BRG (Initial Track, Magnetic)
14. DIS (Leg Distance)
15. ETE (Leg Time)
16. REQ (Fuel Required for Leg)

And for the total flight plan:

1. DIS (Total Distance)
17. ETE (Total Flight Plan Time)
18. REQ (Total Fuel Required)

All you need to input is your cruising speed and your fuel burn. Fuel burn is entered in units / hour. The units are not important providing you use the same units for fuel flow and fuel quantity. If you fill your aircraft tanks using US gallons (or kilograms), enter your fuel flow in USG/hr (kg/hr).

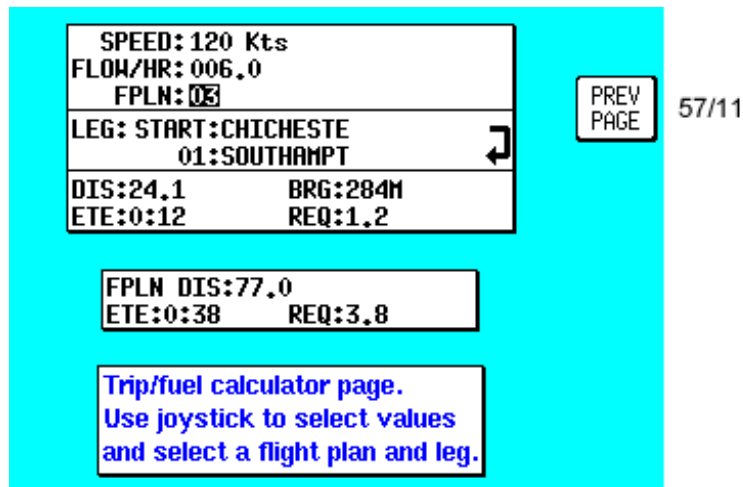

Screen 60: Trip / Fuel Flight Plan Select Screen

On entry to Screen 60, the cursor will be positioned over the flight plan number. Default speed will be 120 knots or that last set. Default flow/hour will be 6.0 or that last set. Moving the joystick up and down alters the flight plan number. Moving the joystick right moves the cursor down to the leg selection. Moving the joystick left moves the cursor up to the flow and speed settings.

When using this function for the first time, move the cursor up to SPEED and set the cruise speed of your aircraft. Move the cursor down to FLOW/HR and set the fuel flow per hour for your aircraft. These settings will be permanently stored for later use.

Next move the cursor down and select the flight plan you want to perform the calculations for and then move the cursor down again to scroll through the legs of your chosen flight plan.

As you scroll through the flight plan, the seven calculated fields in the lower part of the Screen will be updated. The four values grouped together (DIS, BRG, ETE and REQ) are the DIS (Leg Distance), BRG (Initial Track, Magnetic), ETE (Leg Time) and REQ (Fuel required for Leg) for the leg displayed.

The three values grouped below (FPLN DIS, ETE and REQ) are the FPLN DIS (Total flight plan distance), ETE (Total flight plan time) and REQ (Total fuel required, no reserve) for the flight plan displayed.

Sunset/Sunrise Calculator.

This feature is entered by pressing Key 5, SUNSET/RISE, on Screen 57, E6-B Calculator Cover Screen, and allows you to calculate sunrise and sunset times for any point in the world. You will be asked to input a latitude, longitude and date. The sunrise and sunset time for that date will then be displayed in your local time.

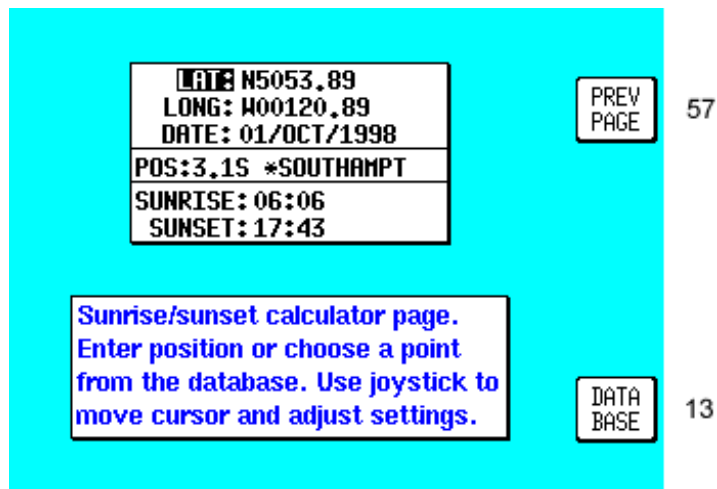

Screen 61: Sunset/Sunrise Calculator Screen

On entry to this Screen the present or last known latitude and longitude will show. The present date (Skymap IIIC only) will also show. If your unit is a Tracker IIIC, a default date value will be displayed.

You can now alter the latitude, longitude and time with the joystick or alter the latitude and longitude by choosing an item from the database. Key 5, DATABASE, calls Screen 13, Database Selection Screen. Once an item is selected, this Screen returns with the item's latitude and longitude and name showing.

The POS, SUNRISE and SUNSET fields are all re-calculated each time you alter the position or date.

Please Note: The Sunrise and Sunset times displayed on this screen are displayed in YOUR LOCAL TIME (i.e. UTC + your local offset), not the local time of the position selected. Allowance must be made if the position you have selected is in a different time zone from that for which the unit is set up for.

APPENDIX A SETUP SCREENS

SETUP SCREENS

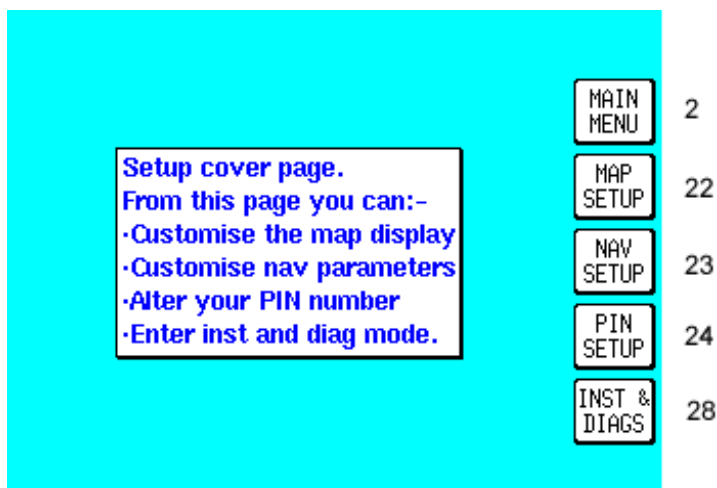

Screen 21: Setup Cover Screen

Your Bendix/King unit allows you a great deal of flexibility to customise it to suit your own wishes and requirements. It also contains a high level of automatic self-testing and diagnostics. All customisation and diagnostic functions are grouped together in this Setup section.

To access Screen 21, Setup Cover Screen press Key 4 SETUP in Main Menu.

Key 1 returns you to Screen 2, Main Menu

Key 10 gives access to Screen 22, Map Customisation Screens.

Key 11 gives access to Screen 23, NAV Mode Customisation Screen.

Key 12 gives access to Screen 24, Personal Identification Number (PIN) Setup Screens.

Key 13 gives access to Screen 28, Installation and Diagnostic Screens.

Map Setup Screens

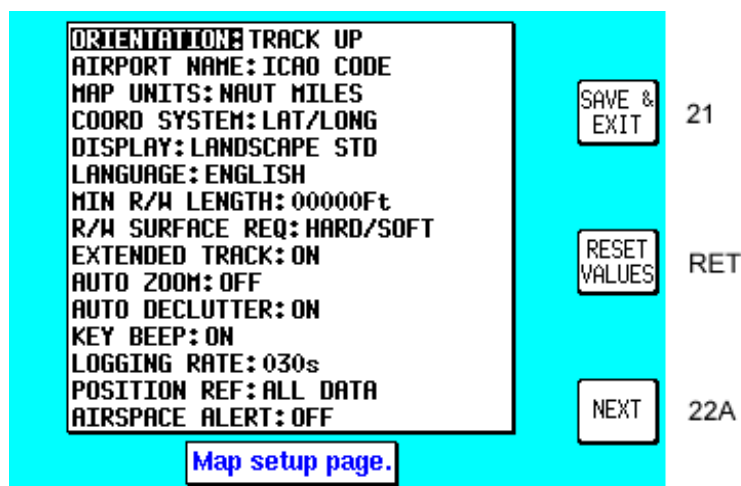

Screen 22: Map Customisation Screen

To access Screen 22, Map Customisation Screen, presses Key 4, SETUP, in Main Menu, followed by Key 2, MAP SETUP, in Screen 21, Setup Cover Screen.

When this Screen first appears you will always see the current settings with a cursor over the words ORIENTATION. You can then use the joystick to move the cursor up and down the list of headings. When the cursor is over the heading you wish to alter, move the joystick to the right. This will in turn move the cursor over to the set of options available for that heading. Moving the joystick up and down will then allow you to scroll through these options.

The various settings available for each heading are listed below. The default settings are those shown in the illustration above. To reset the values on this Screen (or Screens 22A, 22B and 22C) to their defaults, press Key 3 RESET VALUES. This will reset the values on the displayed screen only. In order to reset all user defined data globally, see the Clear Memory screens later in this section.

Settings available:

- ORIENTATION: track up / north up.
- AIRPORT NAMES: ICAO code / Airport name / City name.
- MAP UNITS: nautical miles / statute miles / kilometres.
- COORD SYSTEM: LAT/LON / OSGB / UTM.
- DISPLAY: landscape standard / landscape inverse / portrait standard / portrait inverse
- LANGUAGE: English / French / German / Spanish.
- MIN R/W LENGTH: selectable from 0 to 15 000.
- R/W SURFACE REQUIRED: hard/soft / hard.
- EXTENDED TRACK: on / off.
- AUTO ZOOM: off / on.
- AUTO DECLUTTER: on / off
- KEY BEEP: on / off.
- LOGGING RATE: selectable between 000 (off) and 999 secs.
- POSITION REF: all data / VOR's / VOR's & Airports
- AIRSPACE ALERT: on / off

ORIENTATION: This allows you to choose whether to have the map displayed with north at the top of the screen or orientated to have the aircraft's track aligned up the screen.

AIRPORT NAMES: This gives you the option of labelling the airport icons on the map with the full names of the airports (long ones truncated to 9 characters), the full names of the city associated with the airport or the ICAO 3 or 4 letter location indicators.

MAP UNITS: This allows you to specify the units in which the scale bar and all navigation information will be displayed. If nautical or statute miles are selected, all lengths and altitudes will be reported in feet. If kilometres are selected, all lengths and altitudes will be reported in metres.

COORD SYSTEM: This option controls whether the unit operates with reference to Latitude/Longitude or UTM or OSGB grid references

DISPLAY: Here you can choose the orientation of the display with respect to the keys. Portrait Std mode is usually selected for leg and yoke-mounted operation.

LANGUAGE: Enables you to choose the language in which you would prefer the unit to operate.

MIN R/W LENGTH: This allows you to set the minimum length of main runway at the airports, which will be displayed when you ask the unit to display the ten nearest airports. The minimum length can be specified in steps of 1 foot from 0 to 15,000 feet (or meters if map units are set to kilometres). By setting a minimum length you can force the unit to search for those airports with runways, which are equal to or longer than the pre-set minimum length. To disable this filter set the minimum runway length to 00000 feet.

R/W SURFACE REQUIRED: R/W Surface Required is also used when searching for the ten nearest airports in map mode, if set to hard/soft, airports with either hard or soft runways will be displayed. If set too hard, only airports with hard runways will be displayed and soft-runway airports ignored.

EXT TRACK: If Extended Track is turned on, you will see an extended track line drawn ahead of your present position in the direction of your present track. This can sometimes be useful to see just where the aircraft would end up if the present heading were maintained. Alternatively you can dispense with this map feature simply by selecting EXT TRACK to OFF.

AUTO ZOOM: Auto Zoom is a useful function to use as you approach your destination. When flying the last leg of a flight plan or when flying a DIRECT TO, the zoom range is automatically adjusted. The unit selects the lowest zoom setting that will show the destination and the current aircraft position on the same map image. This automatic selection of the optimum zoom range continues until either the final destination is reached, the flight plan or DIRECT TO is cancelled, or the pilot manually adjusts the map zoom by pressing the ZOOM IN or ZOOM OUT keys.

AUTO DECLUTTER: This unique feature makes the map more readable in areas of high data density by removing unimportant icon labels. Each time the map is redrawn, the data displayed is built up in layers starting with the least important data classes (towns etc) through to the most important data class (airports). With Auto Declutter switched on as the map is being built, if a higher priority icon label is found to clash with a lower priority icon label already on the screen, the lower priority icon label will be removed. This prevents icon label overlaps and clashes producing a clearer map.

KEY BEEP: This allows you to select the beep that occurs when you press a key or move the joystick on or off.

LOGGING RATE: This gives you the choice of how often your position is stored in memory for playback in demo mode or to a PC. A setting of 000 switches the logging function off. A

SETUP SCREENS

total of 2000 fixes are stored in continuous wrap around memory (i.e. newest data overwrites oldest). To calculate total logging time, divide 2000 by the logging rate per minute (30 sec logging rate = 2 per minute). This will give the total logging time in seconds (i.e. 2000 points divided by 2 = 1000 minutes = 16 hours 40 mins).

POSITION REF: This is the geographical item used to describe your position to you in Map Mode. Please refer to the Map Mode Screens Section of this Manual for more details.

AIRSPACE ALERT: As the aircraft travels along its course the track ahead is scanned for airspace boundaries. An alert is given when the aircraft is the distance set in this option from the boundary. This function is disabled by setting AIRSPACE ALERT: OFF here.

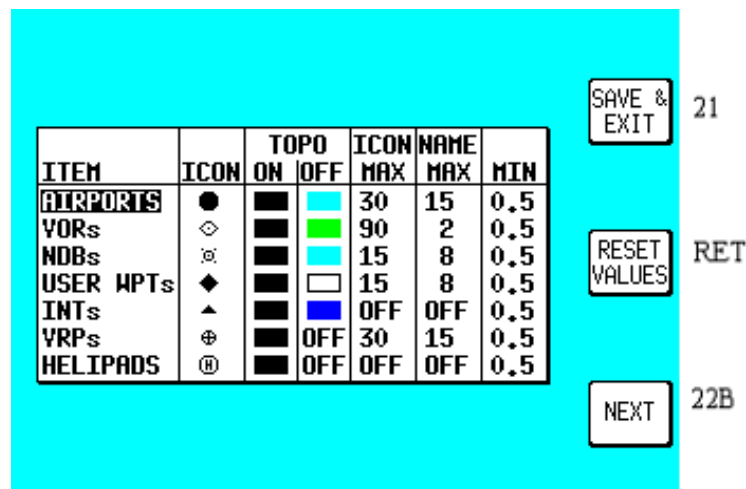

Screen 22A: Point Features Data Class Setup Screen

Screens 22A, 22B and 22C, the Data Class Setup Screens are accessed by repeatedly pressing Key 5, NEXT. It is impossible to include every item from the database within the graphic map display, especially when zoomed out to the smaller scale maps. The Data Class Setup Screens allows you to choose the level of zoom at which you wish each of the classes of data to become visible and at which level of zoom you want their corresponding labels to become visible. You can also configure the appearance of the map to your personal preference for both TOPO ON and TOPO OFF modes.

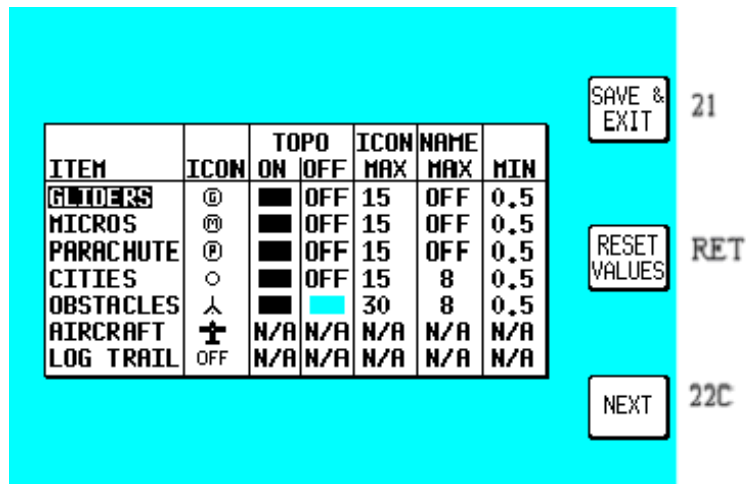

Screen 22B: Cartographical Data Class Setup Screen.

You have the option to select for each database class an ICON or LINE style, A TOPO ON Mode colour, a TOPO OFF Mode colour, an ICON or LINE MAX zoom level (the maximum zoom level at which the icon or line will be displayed), a NAME MAX zoom level (the maximum zoom level at which the name label will be displayed) and a MIN zoom level (the minimum zoom level at which both the icon/line and name will be displayed). The default levels are those shown in the illustrations.

You will notice that there is a limited choice of icon styles for some data classes. This is intentional in order to keep the important data (such as airports) displayed in a recognisable form. You will also notice that some settings have N/A in their columns and are not adjustable. These are items that have fixed values and are not configurable by the user. A good example of this is that you cannot set up a colour for the urban areas in TOPO OFF Mode because no cartography is displayed in TOPO OFF Mode.

Not all data classes shown in the illustrations are available for all geographic areas, for example VRPs are only included in certain data cards. Details of the data classes available on the data card you have installed are available from Bendix/King.

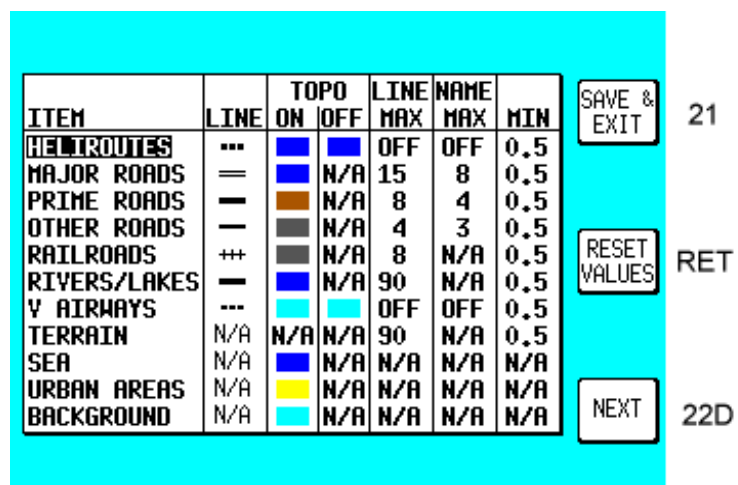

Screen 22C: Line Features Data Class Setup Screen

SETUP SCREENS

ITEM	TOPO		LINE MAX	NAME MAX	MIN	SAVE & EXIT 21
	ON	OFF				
FIR/UTR	■	■	50	30	30	RESET VALUES RET
CLASS A/B/C	■	■	30	15	0.5	
CLASS D	■	■	30	15	0.5	NEXT 22
CLASS E/F/G	■	■	OFF	OFF	0.5	
CLASS UNKNOWN	■	■	30	15	0.5	
DANGER	■	■	50	30	0.5	
RESTRICTED	■	■	50	30	0.5	
PROHIBITED	■	■	50	30	0.5	
MIL/MATZ	■	■	30	15	0.5	
OTHER SUA	■	■	50	30	0.5	

Screen 22D: Airspace Data Class Setup Screen

Please think carefully before altering any of the settings on these screens. You may inadvertently switch off an important data class (such as obstacles), which could compromise your situational awareness.

NAV Mode Setup

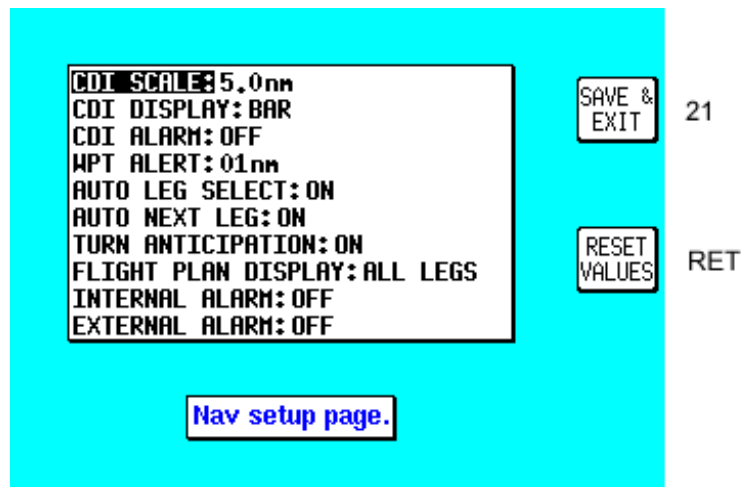

Screen 23: NAV Mode Customisation Screen

When you first enter this Screen the current settings are displayed with a cursor over the words CDI SCALE. You then have to use the joystick to move the cursor up or down. Once the cursor is over the heading you wish to alter, moving the joystick to the right will move the cursor over to the set of options available for that heading.

The various settings available for each heading are listed below. The default settings are those shown in the illustration above. To reset the values on this screen to their defaults, press Key 3 RESET VALUES. This will reset the values on the displayed screen only. In order to reset all user defined data globally, see the Clear Memory screens later in this section.

CDI SCALE: 0.3 / 1.0 / 2.5 / 5.0 nm.

CDI DISPLAY: bar / numeric / off

CDI ALARM: on / off.

WPT ALERT: 1 / 2 / 3 / 4 / 5 / 6 / 7 / 8 / 9 / 10 / 11 / 12 / 13 / 14 / 15 / 16 / 17 / 18 / 19 / 20 nm.

AUTO LEG SELECT: on / off.

AUTO NEXT LEG: on / off.

TURN ANTICIPATION: on / off

FLIGHT PLAN DISPLAY: all legs / active leg.

INTERNAL ALARM: on / off.

EXTERNAL ALARM: on / off.

CDI SCALE: This enables you to choose which of the given distances you want the unit to use as the setting for the full-scale deflection of the Course Deviation Indicator (CDI) in NAV mode

CDI DISPLAY: This allows you to set the CDI display in Map Mode to show either a bar graph, or a numeric read-out of course deviation or to be switched off. If selected OFF, the CDI is no longer shown while you are in Map Mode.

CDI ALARM: When selected ON this produces an audible alarm to tell you when full-scale deflection of the CDI has been reached. If you choose to set this to OFF, you disable this alarm.

WPT ALERT: You can use this feature to set the distance away from a flight plan turning point, or final destination, at which you wish the audio and visual arrival alarm to be

activated.

AUTO LEG SELECT: If you select this ON, the unit will automatically place the cursor on the closest leg when Screen 12, Flight Plan Program / Edit Screen, is accessed to select the flight plan. Although the nearest leg to your present position is highlighted, an alternative leg may be selected by using the joystick. If AUTO LEG SELECT is switched OFF the cursor will simply be positioned over the first leg in the flight plan whenever Screen 12 is selected.

AUTO NEXT LEG: If you select this option ON then, as each waypoint in the flight plan is passed, the next leg will be automatically selected. You thus do not need to press Key 1 (the NEXT LEG Key) as this function produces the same effect automatically. If you select AUTO NEXT LEG to OFF, you will then need to activate the next leg in the flight plan manually by pressing Key 1 (the NEXT LEG Key) at the end of each leg, otherwise your unit will continue to give you distance and bearing information to your previous turning point.

TURN ANTICIPATION: Turn Anticipation provides navigation along a curved path segment to ensure a smooth transition between two adjacent legs in the flight plan. If turned ON, Auto Next Leg will also automatically turn on. Auto Next Leg is an essential part of turn anticipation. Please refer to Arrival at an En-route User Waypoint in the Map Mode with NAV Information Screen section of this manual for more details.

FLIGHT PLAN DISPLAY: Allows a choice of displaying the full flight plan or just the active leg on the map screen.

INTERNAL (ARRIVAL and CDI) ALARM: This gives you the choice between having these internal alarms functioning or inactive.

EXTERNAL (ARRIVAL and CDI) ALARM: This gives you the choice to switch ON or OFF the output from the unit, which can drive an external alarm device.

Personal Identification Number (PIN) Setup

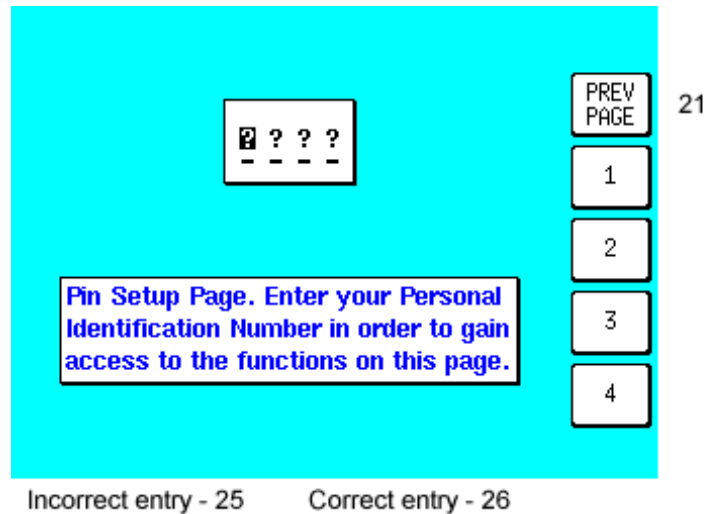

Screen 24: PIN Setup Cover Screen

We have provided the security feature of a Personal Identification Number (PIN) in your Bendix/King unit with the main aim of preventing unauthorised persons from using your navigation equipment. You may use this screen to set up your own choice of a four-digit personal number. This can be any permutation of the figures 1, 2, 3, and 4, e.g. 4412, 2433, 3124 etc.

To access Screen 24, Pin Setup Cover Screen, press Key 4, SETUP, in Main Menu followed by Key 4, PIN SETUP, in Screen 21, Setup Cover Screen. On entry to this Screen you will find the cursor positioned over the first of four question marks. The joystick is not active and the current four-digit PIN must be entered by pressing Keys 2, 3, 4, and 5 (now labelled 1, 2, 3 and 4 as in the illustration above). The default PIN number that will be set when you receive the unit is 1234. As you enter each number by pressing each of the relevant keys once, in the order that matches the PIN, each question mark in turn is replaced by an asterisk and the cursor moves one step to the right. When the last digit is entered, if you have failed to enter the correct four digits, Screen 25 (see illustration below) will be displayed.

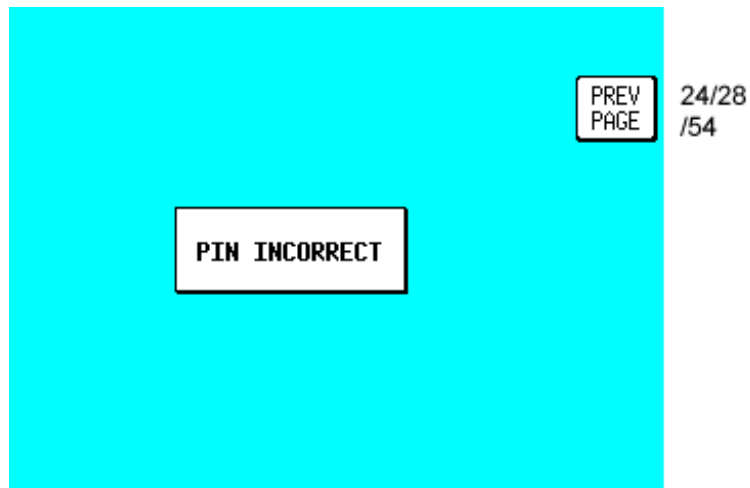

Screen 25: PIN Incorrect Screen

If you get this PIN INCORRECT message, just press Key 1 PREV PAGE and you go back to Screen 24 where you can make another attempt to enter the correct PIN. Unlike many bank Automatic Teller Machines, there is no limit to the number of attempts you can make to input the correct PIN to your Bendix/King unit. Should you have the misfortune to forget your number, keep trying; there are only 256 permutations!

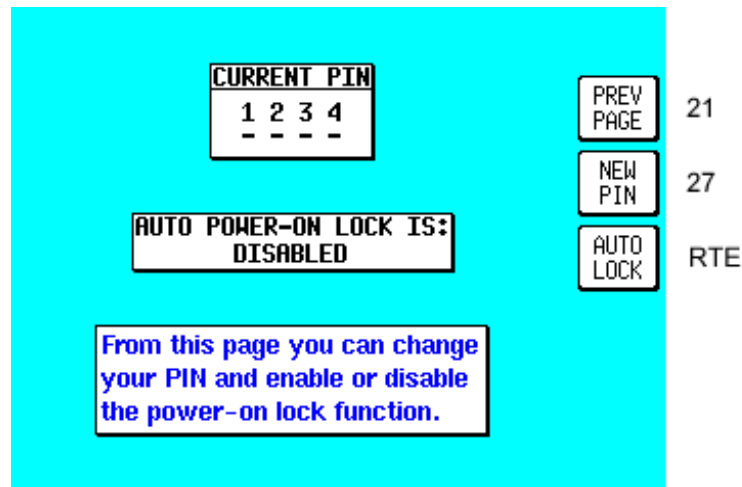

Screen 26: PIN Change & Power-On Lock Enable Screen

If you have entered the correct PIN then you move straight to Screen 26 as illustrated above. On entry to this Screen, the current PIN and the status of the AUTO POWER-ON LOCK are displayed. The default selection for this is DISABLED. If you wish to activate this power-on lock, pressing Key 3, AUTO LOCK, will change the setting to ENABLED.

Pressing Key 1 returns you to Screen 21, the Main Setup page.

Pressing Key 2 takes you into Screen 27 (see below) where you are able to change the PIN.

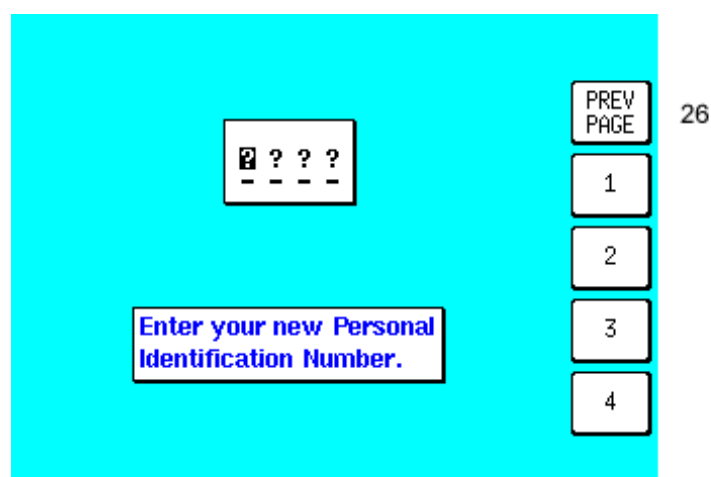

After last digit entry - 26

Screen 27: PIN Change Screen

When you access this Screen the cursor will be sitting over the first question mark. This represents the first digit of the PIN. Your new PIN can be entered from here by pressing Keys 2,3,4 or 5 (now labelled 1,2,3, and 4 in the illustration above). The numbers you enter will replace the question marks as they are entered and the cursor will step to the right.

When the fourth digit has been entered, the new PIN will automatically be transferred to the unit's Non Volatile Memory (NVM) and Screen 26 will be displayed, showing the newly entered PIN. If you wish, you may press Key 1 at any time and this will take you straight to Screen 26 without making any change to the original PIN.

Auto Power-On Lock

Pressing Key 3, AUTO LOCK, on Screen 26, Pin Change & Power On Lock Enable Screen, allows you to switch the Auto Power-On Lock security feature ON or OFF. If you ENABLE the Power-On Lock, the unit will require your PIN to be entered every time you or anyone else switches it on. Although, as mentioned above, so long as the Power-On Lock has **not** been activated, you can key in as many PIN attempts as you wish, once it has been ENABLED however the situation changes entirely.

If an incorrect PIN is then entered three consecutive times at the switch-on stage, the unit will lock out and display Screen 55 (see APPENDIX B). If this happens to you, in order to re-activate the unit, you will have to telephone Honeywell or your Bendix/King dealer, armed with the Serial Number of your unit and the Lock-Out Number, which you can read from the top of Screen 55. The operator at your dealer or at Honeywell will verify these details and check them against the Honeywell database and register of stolen units.

Once the operator is satisfied that the unit has not been stolen and that you are the officially recognised owner, you will be given an Unlock Code Number. This Unlock Number is a 10-digit number. In order to unlock your unit you must now enter this number correctly into your unit, still using Screen 55. The digits will replace the question marks as each one is keyed in. The Unlock Number is regarded by the unit as having been entered as soon as the last digit has been keyed in. Every time an incorrect Unlock Number is entered, the unit will generate a new LOCK OUT number. This makes it impossible for a would-be thief to stumble upon the Unlock Number by trial and error. The odds against a thief guessing the correct Unlock Code Number are 10 million to 1.

SETUP SCREENS

If you do ever get into a Lock-Out situation and then re-activate your unit with the Unlock Code Number received from Honeywell, remember that no matter what PIN you were using before, the PIN will now have been reset to the default digits of 1234.

Be very careful if you activate the Auto Power On Lock feature. Locking yourself out of the system can be very inconvenient.

Installation and Diagnostic Screens

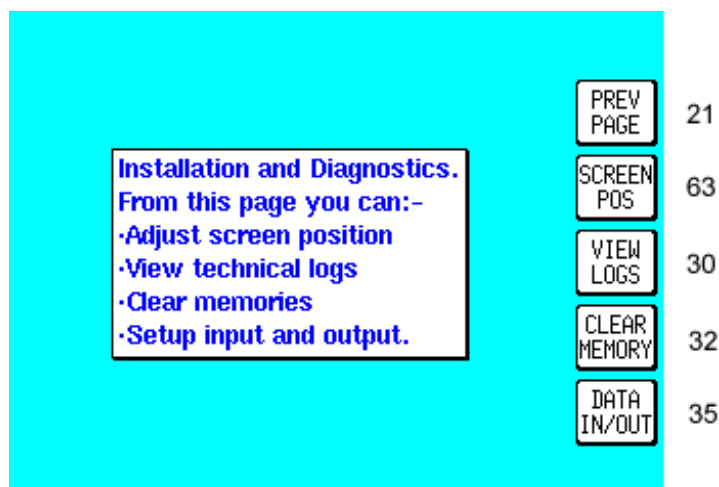

Screen 28: Installation and Diagnostics Cover Screen

This Screen is accessed by pressing Key 4, SETUP, in Main Menu followed by Key 5, INST & DIAGS, in Screen 21, Setup Cover Screen. Screen 28 gives you access to all installation and test-related Screens, and allows you to perform diagnostic checks on the data input and output lines.

You can also use this Screen to gain full access to the “time in service” logs and “last flight” log. It is used, in addition, to enter four different “Memory Clear” routines, which are PIN-protected to prevent inadvertent erasure to the unit's memory.

Key 1 returns you to Screen 21, Setup Cover Screen.

Key 14 calls Screen 63, Screen Position Setup Screen.

Key 15 calls Screen 30, Engineering Log Screen.

Key 16 calls Screen 32, Memory Clear Entry Screen.

Key 17 calls Screen 35, Data In/Out and Test Screen.

Screen Position Setup

Screen 63 is for use during manufacture to position the picture centrally in the viewable area of the display. This screen is also used to focus the image on the display. It is not a Screen with which you as user of the Skymap IIIC would normally use. This screen is protected by a maintenance PIN number.

View Logs

Engineering Log

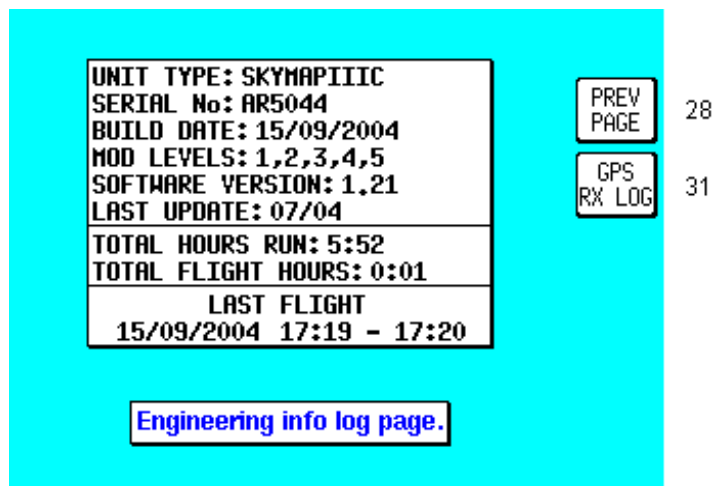

Screen 30: Engineering Log Screen

This Screen can be used to produce technical engineering information about the unit. Unit type, serial number, hardware configuration and build date information were all stored within the Non Volatile Memory at the time your unit was initialised at the factory. The version of the software in use and the latest update information are stored on the data card.

The Total Hours Run value is updated every minute. This can give you an indication of the total time that the unit has been in operation. You can, however reset this figure, using Screen 33. The Total Flight Hours is a value stored in exactly the same way as Total Hours Run, the difference between these two figures being due to the fact that Flight Hours are totalled only during periods when the Ground Speed is above 20 knots. Last Flight data is available only with the Skymap IIC. The Date and Start Time are logged as soon as the Ground Speed exceeds 20 knots and the Stop Time is logged whenever the Ground Speed drops back to less than 3 knots. Key 2, GPS RX LOG, is available only on Skymap IIC units and gives access to the GPS Receiver Engineering Log Screen 31.

GPS Receiver Information Log

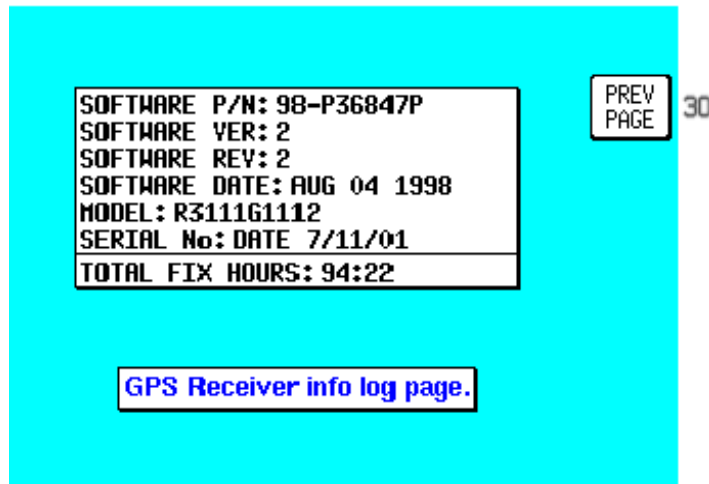

Screen 31: GPS Receiver Information Screen (Skymap IIIC only)

Most of the information on this Screen is technical engineering information about the internal GPS receiver. The Total Fix Hours figure increases only during the periods when the GPS receiver has a 2D or 3D fix. You can if you wish also reset these figures along with the Total Unit Hours Run value by using Screen 33, Memory Clear Screen.

Clear Memory

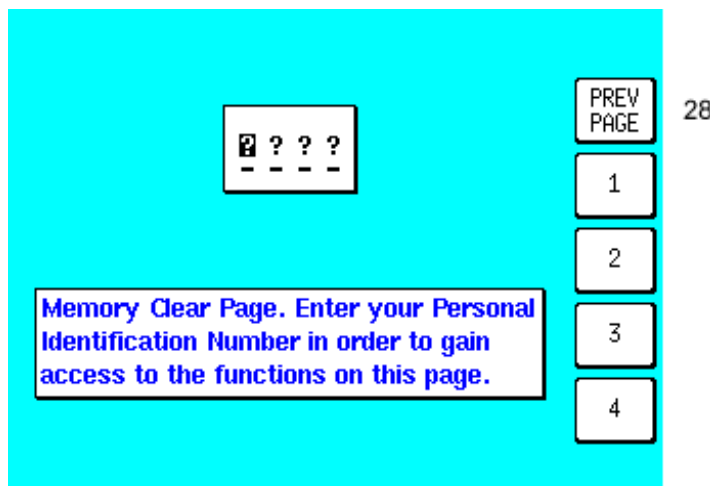

Screen 32: Memory Clear Entry Screen

All the routines, which can clear the unit's memory are protected by your PIN, specifically to prevent any unauthorised person wiping out the valuable data contained in memory. Therefore, when you enter this Screen the cursor will be positioned over the first of four question marks. You must enter your PIN at this stage before you can proceed to the memory clear functions on Screen 33. (The factory default PIN is 1234). As soon as the fourth digit of a correct PIN is entered, the unit will call Screen 33. If the PIN entered is incorrect the display will switch immediately to Screen 25 (PIN INCORRECT) and then take you back to Screen 28, the Cover Screen for Installation and Diagnostics. If you do make a mistake, however, you are allowed to make as many attempts as you need to

SETUP SCREENS

enter the correct PIN.

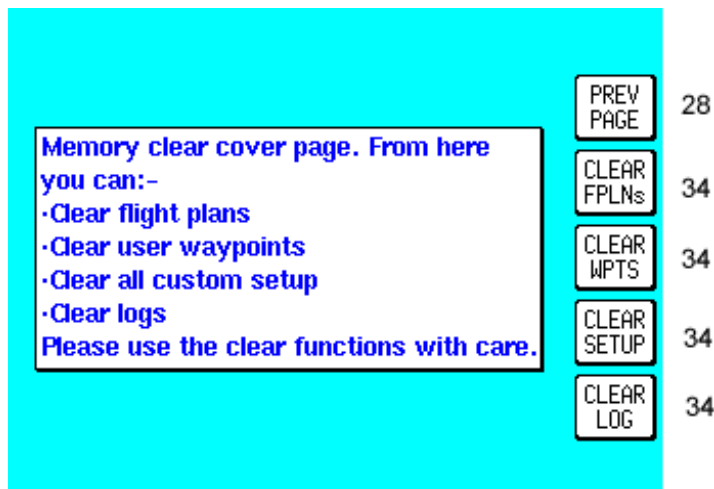

Screen 33: Memory Clear Cover Screen

Be careful to handle operations from this Screen correctly, otherwise you could lose valuable and important data from the memory of your unit. There is no “undelete” function in the Skymap IIC or Tracker IIC.

If for instance you press Key 2, labelled “CLEAR FPLNs”, you will go straight to a warning Screen that reads “Clear Memory. ARE YOU SURE?” If you then press Key 1 labelled “PREV PAGE” it will take you back to Screen 33 again, without erasing any of the memory. If however you decide to go ahead and press Key 5 labelled “YES” then all the flight plans will be completely erased from the unit’s memory and you will not thereafter be able to recall this information.

If you press Key 3, labelled “CLEAR WPTS”, a similar procedure will be followed, and pressing “YES” will this time clear all User Waypoints from memory including those being used in flight plans.

Use of Key 4, labelled “CLEAR SETUP”, will reset all the User-Defined Options within the unit to their original default values. This also clears the Note Pad memory.

Key 5, labelled “CLEAR LOG”, resets the Total Time Run counters that appear on Screens 30 and 31. This also clears the last flight time log and the 2000 in flight logged points from memory.

Key 1, labelled “PREV PAGE”, returns you to Screen 28 without altering or erasing anything in the unit’s memory.

Data In/Out

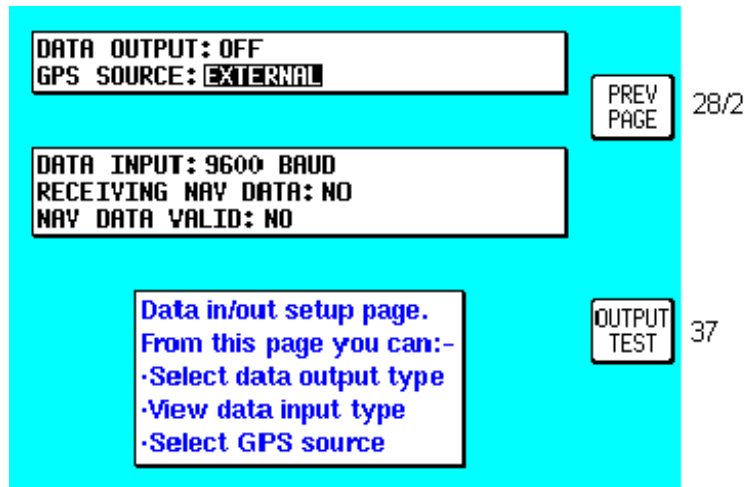

Screen 35: Data Input/Output Setup and Test Screen

On entry to this Screen details of the current settings for data output and GPS Source are displayed in the top box. Settings can be toggled by using the joystick and the options available are as follows. (The default settings are listed first.)

Tracker IIC: DATA OUTPUT: OFF / ECHO INPUT.

Skymap IIC: DATA OUTPUT: OFF / RS232 (ARNAV) 9600 BAUD / NMEA 0183 4800 BAUD / AVIONICS INTERFACE.

The GPS SOURCE allows you to use your Skymap IIC as a Tracker IIC. When you move the cursor to the right of this field the following warning / confirmation request is displayed:

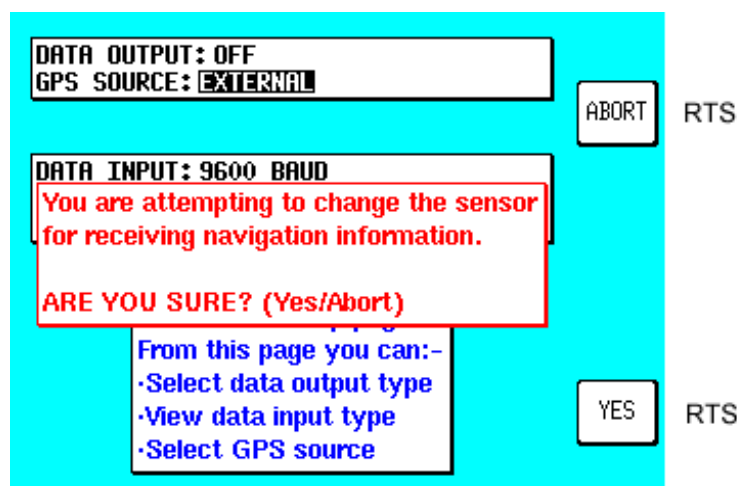

Screen 35B: GPS Source Change Warning Screen

If you press ABORT the GPS source remains unchanged. If you press YES, you can use the joystick to toggle the GPS SOURCE between INTERNAL and EXTERNAL. When set to INTERNAL, the internal GPS receiver will be used, and key 3 will be displayed, to allow access to the GPS Status screen. When set to EXTERNAL, the Skymap IIC will enter Tracker Mode and use data generated by an external GPS receiver in the same way as a

SETUP SCREENS

Tracker IIC does. If you have a Tracker IIC and select INTERNAL, an error message will be displayed because an internal GPS receiver will not be found.

Data output on Tracker IIC is limited to echoing the data input. This provides a useful RS232 buffer for connecting other listening devices to your GPS data output.

Skymap IIC can output standard aviation RS232 data at 9600 baud or NMEA 0183 format RMC, GGA and RMB sentences at 4800 baud. See APPENDIX F for full details.

The AVIONICS INTERFACE output setting for Skymap IIC is for use when connected to the Bendix/King Avionics Interface Module (AIM). The AIM is an optional accessory allowing you to connect your Skymap IIC to other aircraft instruments including the Autopilot. Key 4 will only appear if the AVIONICS INTERFACE output is selected and calls Screen 37, the output test page (Skymap IIC only).

The second box is for information only, and is only shown when the GPS Source is External. The unit will automatically sense the type of incoming data. It first sets up the default data type and then if the incoming data is not recognised, it steps through the other data input options until it finds a format it recognises.

The data type the unit is looking for will be displayed next to the DATA INPUT heading. Once a valid format is found, searching will be disabled. Valid data input types are NMEA, AR-NAV (RS 232) and Northstar binary data at either 1200, 4800 or 9600 baud. See the section on Data Input for further details.

Once a valid format is recognised and sentences are being decoded, the word YES will be displayed next to RECEIVING DATA. If the data is not recognised or is not present, the word NO will be displayed. If the position information in the data being received is valid and useable, the word YES will appear next to the words DATA VALID, if not then the word NO will be displayed.

When Skymap IIC is used with an external GPS source, the data output will be limited to OFF and ECHO INPUT.

Output Test

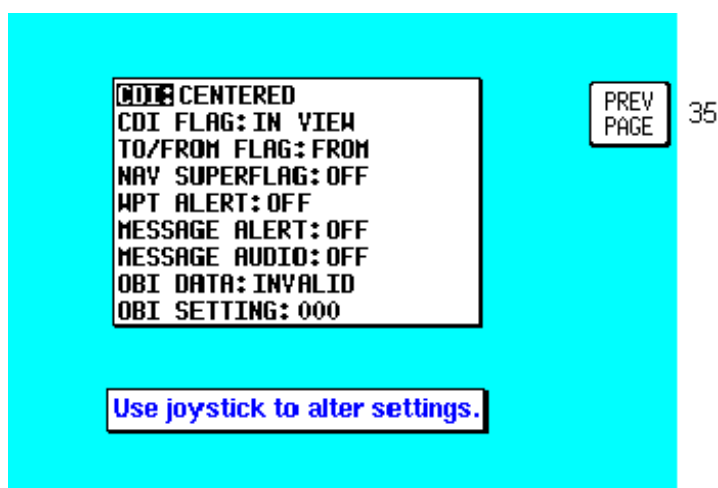

Screen 37: Aviation Interface Output Test Screen (Skymap IIC only)

This Screen is designed to output test data to a Bendix/King Avionics Interface Module (AIM) for use during installation and testing. It is not a Screen with which you as user of

the Skymap IIIC need greatly concern yourself. Should you inadvertently enter it (by pressing Key 4 on Screen 35) you can return to Screen 35 simply by pressing Key 1, labelled PREV PAGE.

APPENDIX B WARNING SCREENS

RAM Lost Warning

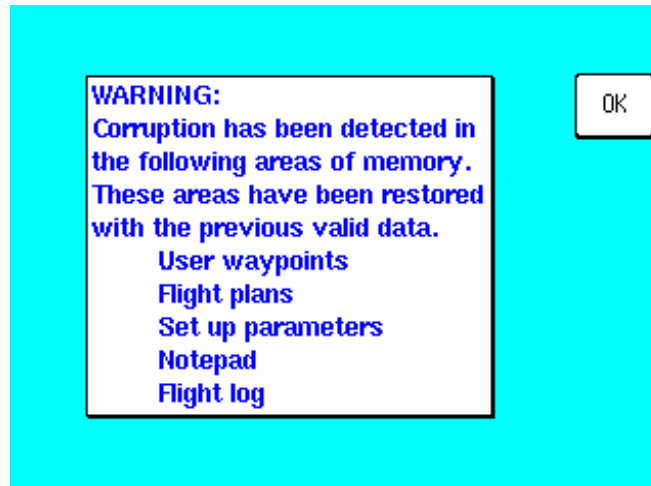

Screen 51: RAM Lost Warning Screen

This screen is displayed after power-on if any of the RAM areas are found to be corrupted. Key 1 invokes a RAM clear to be carried out on the failed area and the last known good values to be reinstated. If the last known good values are also suspect, a full RAM clear of the affected data will be carried out.

Memory Battery Warning

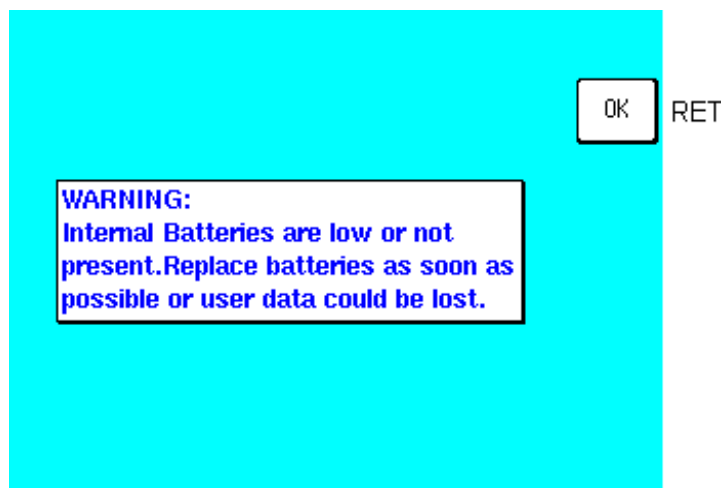

Screen 52: Memory Battery Warning Screen

This Screen will appear if during initialisation the memory battery voltage is found to be low. It can also appear at any time during operation if the internal battery falls below a pre-determined limit.

By pressing Key 1 you can return to whichever Screen was showing before the low voltage condition was detected. **If this screen is displayed, you should have your memory battery replaced by your Bendix/King dealer at the earliest possible opportunity.**

PIN Lock Warning

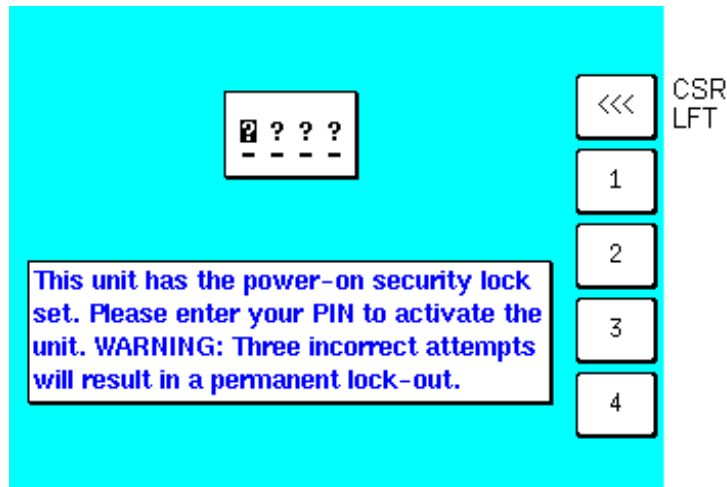

Screen 54: Power On Security PIN Entry Screen

If the Auto Power-On Lock function has been activated on Screen 26, this Screen will be called during initialisation. You must then input the correct PIN before you are allowed to move back to Screen 1 with full access to all functions.

If an incorrect PIN is entered, Screen 25 will appear and Key 1 will revert to this Screen. If an incorrect PIN is entered on three consecutive attempts, **even if the unit has been switched off and back on again between attempts**, Screen 55 will appear. The number of incorrect attempts that have been made is stored in NVM and increased with each incorrect attempt or cleared down once you have managed to enter the correct PIN.

As the PIN is entered, asterisk characters are displayed in place of the question marks. Key 1 can be used as a Back-Space Key.

Lock Out Warning

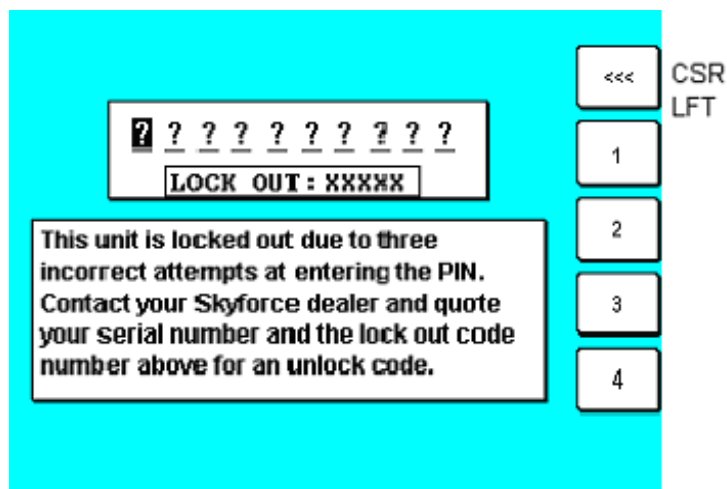

Screen 55: Lockout Screen

This Screen will only appear after three incorrect PIN's have been entered on Screen 54 (or if when you switch the unit on the NVM is found to have accumulated three

unsuccessful PIN input attempts).

The LOCK OUT number is a random five digit number that the unit generates. This is held in RAM and does not change until an unlock number is entered. The unit can be switched off and on with this Screen showing but the LOCK OUT number will remain the same.

If you get locked out of the unit, in order to re-activate the unit, you will need to telephone Honeywell or your local Bendix/King dealer and provide them with your Serial Number and the Lockout Number. Your details will be verified and checked against the Honeywell database and register of stolen units. Once the operator is satisfied that the unit has not been stolen and that you are the officially recognised owner, you will be given an Unlock Code Number.

This Unlock Code is a 10-digit number. You must enter this into your unit on Screen 55. The digits will replace the question marks as each one is entered. The Unlock Number is deemed to be entered as the last digit is input. Every time an incorrect unlock number is entered, the unit will generate a new LOCK OUT number. This makes it impossible for a would be thief to stumble upon the unlock number by trial and error. The chances of guessing the correct unlock code are 10 million to 1.

Once a lock out has occurred and the unit has been re-activated with an unlock number, the PIN will be reset to the default of 1234.

Be very careful if you activate the Auto Power On Lock feature. Locking yourself out of the system can be very inconvenient.

New Data Card Warning

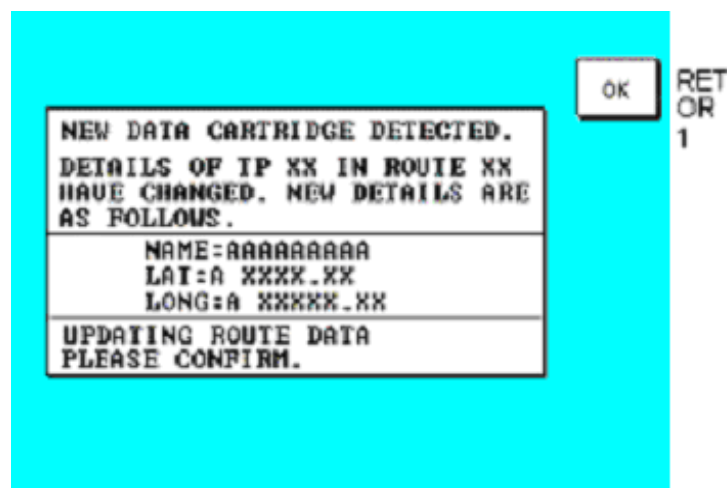

Screen 56: Flight Plan Change Warning Screen

If, during initialisation, the unit detects a new memory card, the software will check through the flight plans programmed into the unit and validate the data.

Whenever you build a flight plan by using items from the memory card, the Name, Lat. and Long of each chosen item is copied into RAM along with a note of which database and which country you selected it from. When a new memory card is detected, each item in each flight plan is checked against the new database.

This is done by reading the first item from the first flight plan in RAM and conducting a

WARNING SCREENS

search through the relevant part of the new memory card looking for a name match. If a perfect match is found for the Name, then the Lat. and Long are then checked and if they match correctly also, then no action is required and the software goes on to check the next item.

If a discrepancy is found in either Lat. or Long, Screen 56 will appear showing the new information for the waypoint in question. You must confirm that you are aware of the change by pressing Key 1.

If no match can be found for the name (i.e. the name has been changed or the item has been deleted from the new database) the Lat. and Long fields on Screen 56 will be left blank and the bottom section of the box will read:

**CHANGING DATABASE REFERENCE
PLEASE CONFIRM**

Pressing Key 1 will change the database reference displayed on Screen 12, Flight Plan Program/Edit Screen, to OW indicating that this item is now an Old Waypoint and is no longer accessible from any database.

This check is carried out for every point in every flight plan and whenever discrepancies are found, Screen 56 will appear on each occasion.

APPENDIX C MEMORY CARDS

MEMORY CARDS

Data Areas

Bendix/King produce a series of memory cards (based on the standard ICAO/ARINC geographic areas) for Skymap IIC and Tracker IIC that cover the entire world. Each card for each area contains the operating software, the appropriate Jeppesen aeronautical data and cartographic data to a high resolution. Also included is a low-resolution map of the rest of the world.

The ten ICAO/ARINC areas along with their three letter identifiers are:

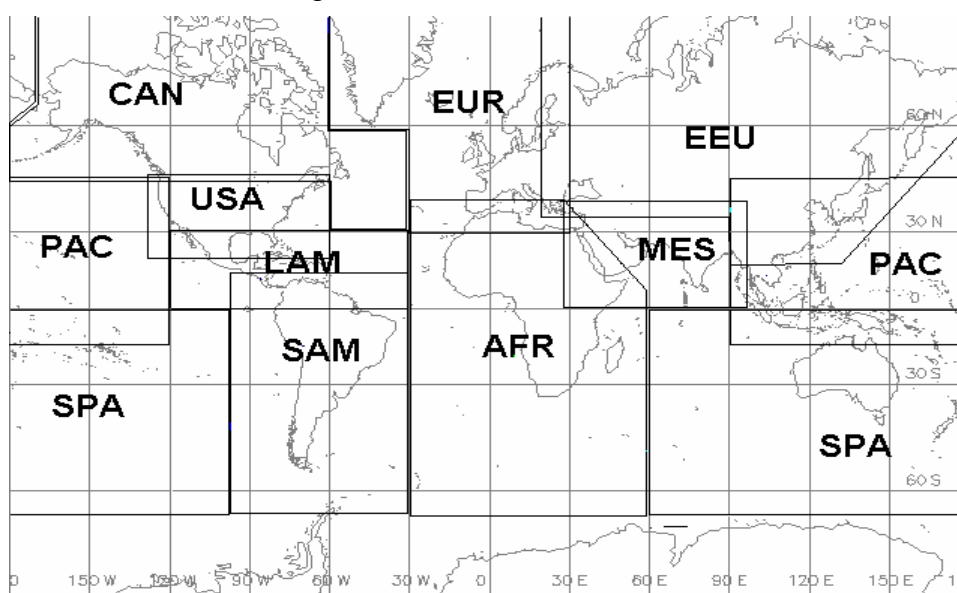

EUR Europe
USA USA
SPA South Pacific
SAM South America

CAN Canada
PAC Pacific
LAM Latin America

MES Middle East
EEU Eastern Europe
AFR Africa

These areas are combined in various ways to produce memory Cards. There are three large area cards available which between them cover the entire world and contain the following data:

AMR Americas - comprising CAN, USA, LAM, SAM

ATI Atlantic International - comprising EUR, AFR, EEU, MES

PAI Pacific International - comprising PAC, SPA, EEU, MES

Other area combinations are also available. Please contact your Bendix/King Dealer for full details of data card availability.

Changing the memory card

To change the Data Card follow these simple steps:

1. Remove the power/data plug and place the unit face down on a soft surface. A piece of foam or a cushion is ideal. Remove the case back by rotating the two screw fasteners one turn counter clockwise.

19. Grasp the data card by its edges and pull it straight out of its socket. Do not twist the Card out of the socket, this could bend or break the gold pins. Being careful to align the card with the socket then press the new card firmly into place.
20. Refit the case back being careful that the blue gasket is properly seated. **Do not exert undue downward force on the screw fasteners.** Let them pull the case back into place. Switch the unit on and check for correct operation. Screen 56 may be displayed if changes to information featured in your flight plans are detected. Please refer to the NAV Data Card Warning in APPENDIX B .

Minimum Safe Altitudes (MSA)

Included in the Jeppesen data supplied on your memory card is Grid Minimum Off Route Altitude (Grid MORA) data. The correct use of this data is very important for terrain avoidance and hence requires some further explanation.

This data is split into a series of one degree square tiles for the entire world. The Grid MORA provides reference point clearance within these tiles. Jeppesen define a reference point as a natural (peak, knoll, hill, etc) or man-made (tower, stack, tank, building, etc) object.

Jeppesen state that Grid MORA values clear all reference points by 1000 feet in areas where the highest reference points are 5000 feet MSL or lower. MORA values clear all reference points by 2000 feet in areas where the highest reference points are 5001 feet MSL or higher. Grid MORAs are defined for all areas.

In Skymap IIIC the Grid MORA information is used in two ways to derive Minimum Safe Altitudes (MSA), firstly during flight plan building and secondly during actual flight.

Flight Plan building.

On screen 12, the Flight Plan Program / Edit Screen, as the cursor is moved up and down the flight plan, the MSA for that leg is shown in a box below the LEG and FPLN info box as [LEG MSA: XXXX]. This value is the highest value Grid MORA found along a ten mile wide corridor (including 5 miles past the waypoint) centred along each leg. Also shown is [FPLN MSA: XXXX] which is the highest value leg MSA for the entire flight plan.

During Flight

An [MSA:XXXX] box is included on screen 41, the NAV Menu Screen. This displays the highest Grid MORA value within a ten-mile radius of your present position at all times.

WARNING: The MSA altitudes displayed are advisory in nature only. They should not be relied upon as the sole source of obstacle and terrain avoidance information. Always refer to current aeronautical charts for appropriate minimum clearance altitudes.

Worldwide ICAO Codes.

In order to aid use of the Skymap IIC, especially the area filter used during database selection (Screens 16 and 16A), there follows a full list of all the Countries and States that feature in the Jeppesen database along with their ICAO codes, Jeppesen standard name and the data area in which they are included (refer to the map at the beginning of this appendix).

Official Country Name	ICAO	Jeppesen Standard Name	State	Area
ACCRA FIR	DG	ACCRA FIR		AFR
ALGERIA, P. DEMOCRATIC REP OF	DA	ALGERIA	DZA	AFR
ANGOLA, REPUBLIC OF	FN	ANGOLA	AGO	AFR
ANTANANARIVO FIR/UIR	FM	ANTANANARIVO FIR/UIR		AFR
ANTARCTICA (AFR, INDIAN OC)	F1	ANTARCTICA (AFR)		AFR
ASCENSION I	FH	ASCENSION	SHN	AFR
BENIN, PEOPLES REPUBLIC OF	DB	BENIN	BEN	AFR
BOTSWANA, REPUBLIC OF	FB	BOTSWANA	BWA	AFR
BRAZZAVILLE FIR/UIR	FC	BRAZZAVILLE FIR/UIR		AFR
BRITISH INDIAN OCEAN TR.	FJ	BRITISH INDIAN OCEAN TR	IOT	AFR
BURKINA FASO	DF	BURKINA FASO	BFA	AFR
BURUNDI, REPUBLIC OF	HB	BURUNDI	BDI	AFR
CAMEROON, UNITED REPUBLIC OF	FK	CAMEROON	CMR	AFR
CANARY ISLANDS (SPAIN)	GC	CANARY IS	ESP	AFR
CAPE VERDE, REPUBLIC OF	GV	CAPE VERDE	CPV	AFR
CENTRAL AFRICAN REPUBLIC	FE	CENTRAL AFRICAN REP	CAF	AFR
CHAD, REPUBLIC OF	FT	CHAD	TCD	AFR
CHAGOS ARCHIPELAGO	FJ	CHAGOS ARCHIPELAGO	IOT	AFR
COMOROS, ISLAMIC FED REP OF	FM	COMOROS	COM	AFR
CONGO, REPUBLIC OF THE	FC	CONGO	COG	AFR
DAKAR FIR/UIR	GO	DAKAR FIR/UIR		AFR
DAKAR OCEANIC	GO	DAKAR OCEANIC		AFR
DAKHLA AND LAAYOUNE	GM	DAKHLA AND LAAYOUNE		AFR
DJIBOUTI, REPUBLIC OF	HD	DJIBOUTI	DJI	AFR
EGYPT, ARAB REPUBLIC OF	HE	EGYPT	EGY	AFR
EQUATORIAL GUINEA, REPUBLIC OF	FG	EQUATORIAL GUINEA	GNQ	AFR
ERITREA	HH	ERITREA	ERI	AFR
ETHIOPIA	HA	ETHIOPIA	ETH	AFR
GABONESE REPUBLIC	FO	GABON	GAB	AFR
GAMBIA, REPUBLIC OF THE	GB	GAMBIA	GMB	AFR
GHANA, REPUBLIC OF	DG	GHANA	GHA	AFR
GUINEA, REVOL PEOPLES REP OF	GU	GUINEA REP	GIN	AFR
GUINEA-BISSAU, REPUBLIC OF	GG	GUINEA-BISSAU	GNB	AFR
IVORY COAST, REPUBLIC OF	DI	IVORY COAST	CIV	AFR
JOHANNESBURG FIR	FA	JOHANNESBURG FIR		AFR
KENYA, REPUBLIC OF	HK	KENYA	KEN	AFR
LESOTHO, KINGDOM OF	FX	LESOTHO	LSO	AFR
LIBERIA, REPUBLIC OF	GL	LIBERIA	LBR	AFR
MALAGASCAR, REPUBLIC OF	FM	MADAGASCAR	MDG	AFR
MALAWI, REPUBLIC OF	FW	MALAWI	MWI	AFR
MALI, REPUBLIC OF	GA	MALI	MLI	AFR
MAURITANIA, ISLAMIC REPUBLIC	GQ	MAURITANIA	MRT	AFR
MAURITIUS FIR	FI	MAURITIUS FIR		AFR
MAYOTTE	FM	MAYOTTE	MYT	AFR
MELILLA (SPAIN)	GE	MELILLA	ESP	AFR
MOROCCO, KINGDOM OF	GM	MOROCCO	MAR	AFR

MEMORY CARDS

Official Country Name	ICAO	Jeppesen Standard Name	State	Area
MOZAMBIQUE, REPUBLIC OF	FQ	MOZAMBIQUE	MOZ	AFR
N'DJAMENA FIR/UIR	FT	N'DJAMENA FIR/UIR		AFR
NAIROBI FIR	HK	NAIROBI FIR		AFR
NAMIBIA	FY	NAMIBIA	NAM	AFR
NIAMEY FIR/UIR	DR	NIAMEY FIR/UIR		AFR
NIGER	DR	NIGER	NER	AFR
NIGERIA, FEDERAL REPUBLIC OF	DN	NIGERIA	NGA	AFR
REPUBLIC OF MAURITIUS	FI	MAURITIUS	MUS	AFR
REUNION, DEPARTMENT OF	FM	REUNION	REU	AFR
ROBERTS FIR	GL	ROBERTS FIR		AFR
RWANDESE REPUBLIC	HR	RWANDA	RWA	AFR
SAINT HELENA	FH	ST HELENA	SHN	AFR
SAL OCEANIC	GV	SAL OCEANIC		AFR
SAO TOME & PRINCIPE, DEM REP	FP	SAO TOME AND PRINCIPE	STP	AFR
SENEGAL, REPUBLIC OF	GO	SENEGAL	SEN	AFR
SEYCHELLES FIR	FS	SEYCHELLES FIR		AFR
SEYCHELLES, REPUBLIC OF	FS	SEYCHELLES	SYC	AFR
SIERRA LEONE, REPUBLIC OF	GF	SIERRA LEONE	SLE	AFR
SOC PEO LIBYAN ARAB JAMAHIRIYA	HL	LIBYA, SPA JAMAHIRIYA	LBY	AFR
SOMALI DEMOCRATIC REPUBLIC	HC	SOMALIA	SOM	AFR
SOUTH AFRICA, REPUBLIC OF	FA	SOUTH AFRICAN REP	ZAF	AFR
SUDAN, REPUBLIC OF THE	HS	SUDAN	SDN	AFR
SWAZILAND, KINGDOM OF	FD	SWAZILAND	SWZ	AFR
TANZANIA, UNITED REPUBLIC OF	HT	TANZANIA	TZA	AFR
TOGOLESE REPUBLIC	DX	TOGO	TGO	AFR
TUNISIA, REPUBLIC OF	DT	TUNISIA	TUN	AFR
UGANDA, REPUBLIC OF	HU	UGANDA	UGA	AFR
ZAIRE, REPUBLIC OF	FZ	ZAIRE	ZAR	AFR
ZAMBIA, REPUBLIC OF	FL	ZAMBIA	ZMB	AFR
ZIMBABWE, REPUBLIC OF	FV	ZIMBABWE	ZWE	AFR

Official Country Name	ICAO	Jeppesen Standard Name	State	Area
ALASKA	PA	ALASKA	USA	CAN
ALBERTA	CY	ALBERTA	CAN	CAN
BRITISH COLUMBIA	CY	BRITISH COLUMBIA	CAN	CAN
CANADA	CY	CANADA	CAN	CAN
MANITOBA	CY	MANITOBA	CAN	CAN
NEW BRUNSWICK	CY	NEW BRUNSWICK	CAN	CAN
NEWFOUNDLAND	CY	NEWFOUNDLAND	CAN	CAN
NORTHWEST TERRITORIES	CY	NORTHWEST TERRITORIES	CAN	CAN
NOVA SCOTIA	CY	NOVA SCOTIA	CAN	CAN
ONTARIO	CY	ONTARIO	CAN	CAN
PRINCE EDWARD ISLAND	CY	PRINCE EDWARD ISLAND	CAN	CAN
QUEBEC	CY	QUEBEC	CAN	CAN
SAINT PIERRE AND MIQUELON	CF	ST PIERRE I	SPM	CAN
SAINT PIERRE AND MIQUELON	CF	MIQUELON I	SPM	CAN
SASKATCHEWAN	CY	SASKATCHEWAN	CAN	CAN
YUKON TERRITORY	CY	YUKON TERRITORY	CAN	CAN

Official Country Name	ICAO	Jeppesen Standard Name	State	Area
ARMENIA, REPUBLIC OF	UG	ARMENIA	ARM	EEU
AZERBAIJANI REPUBLIC	UB	AZERBAIJAN	AZE	EEU
BELARUS, REPUBLIC OF	UM	BELARUS	BLR	EEU
BULGARIA, REPUBLIC OF	LB	BULGARIA	BGR	EEU
CHINA, PEOPLES REPUBLIC OF	ZB	CHINA, PR OF	CHN	EEU
CHINA, PEOPLES REPUBLIC OF	ZG	CHINA, PR OF	CHN	EEU
CHINA, PEOPLES REPUBLIC OF	ZL	CHINA, PR OF	CHN	EEU
CHINA, PEOPLES REPUBLIC OF	ZP	CHINA, PR OF	CHN	EEU
CHINA, PEOPLES REPUBLIC OF	ZU	CHINA, PR OF	CHN	EEU
CHINA, PEOPLES REPUBLIC OF	ZY	CHINA, PR OF	CHN	EEU
CHINA, PEOPLES REPUBLIC OF	ZW	CHINA, PR OF	CHN	EEU
CHINA, PEOPLES REPUBLIC OF	ZH	CHINA, PR OF	CHN	EEU
CHINA, PEOPLES REPUBLIC OF	ZS	CHINA, PR OF	CHN	EEU
CZECH REPUBLIC	LK	CZECH	CZE	EEU
GEORGIA, REPUBLIC OF	UG	GEORGIA	GEO	EEU
HUNGARIAN PEOPLE'S REPUBLIC	LH	HUNGARY	HUN	EEU
KAZAKHSTAN, REPUBLIC OF	UT	KAZAKHSTAN	KAZ	EEU
KAZAKHSTAN, REPUBLIC OF	UA	KAZAKHSTAN	KAZ	EEU
KAZAKHSTAN, REPUBLIC OF	UR	KAZAKHSTAN	KAZ	EEU
KOREA, DEMOCRAT PEOPLES REP OF	ZK	KOREA, DPR OF	PRK	EEU
KYRGYZ REPUBLIC	UA	KYRGYZSTAN	KGZ	EEU
LATVIA, REPUBLIC OF	EV	LATVIA	LVA	EEU
LITHUANIA, REPUBLIC OF	EY	LITHUANIA	LTU	EEU
MOLDOVA, REPUBLIC OF	LU	MOLDOVA	MDA	EEU
MONGOLIA	ZM	MONGOLIA	MNG	EEU
POLISH PEOPLES REPUBLIC	EP	POLAND	POL	EEU
REPUBLIC OF ESTONIA	EE	ESTONIA	EST	EEU
ROMANIA, SOCIALIST REPUBLIC OF	LR	ROMANIA	ROM	EEU
RUSSIAN FEDERATION	UN	RUSSIA	RUS	EEU
RUSSIAN FEDERATION	US	RUSSIA	RUS	EEU
RUSSIAN FEDERATION	UM	RUSSIA	RUS	EEU
RUSSIAN FEDERATION	UR	RUSSIA	RUS	EEU
RUSSIAN FEDERATION	UE	RUSSIA	RUS	EEU
RUSSIAN FEDERATION	UH	RUSSIA	RUS	EEU
RUSSIAN FEDERATION	UU	RUSSIA	RUS	EEU
RUSSIAN FEDERATION	UL	RUSSIA	RUS	EEU
RUSSIAN FEDERATION	UO	RUSSIA	RUS	EEU
RUSSIAN FEDERATION	UI	RUSSIA	RUS	EEU
RUSSIAN FEDERATION	UW	RUSSIA	RUS	EEU
SLOVAK REPUBLIC	LZ	SLOVAKIA	SVK	EEU
TAJIKISTAN, REPUBLIC OF	UT	TAJIKISTAN	TJK	EEU
TURKMENISTAN	UT	TURKMENISTAN	TKM	EEU
UKRAINE	UK	UKRAINE	UKR	EEU
UZBEKISTAN, REPUBLIC OF	UT	UZBEKISTAN	UZB	EEU
ALBANIA, REPUBLIC OF	LA	ALBANIA	ALB	EUR
AUSTRIA, REPUBLIC OF	LO	AUSTRIA	AUT	EUR
AZORES (PORTUGAL)	LP	AZORES	PRT	EUR
BELGIUM	EB	BELGIUM	BEL	EUR
BOSNIA AND HERZEGOVINA, LQ REP OF	LQ	BOSNIA AND HERZEGOVINA	BIH	EUR

MEMORY CARDS

Official Country Name	ICAO	Jeppesen Standard Name	State	Area
CROATIA, REPUBLIC OF	LD	CROATIA	HRV	EUR
DENMARK	EK	DENMARK	DNK	EUR
FAROE ISLANDS (DENMARK)	EK	FAROE IS	FRO	EUR
FINLAND	EF	FINLAND	FIN	EUR
FRENCH REPUBLIC	LF	FRANCE	FRA	EUR
GERMANY, FEDERAL REPUBLIC OF	ET	GERMANY	DEU	EUR
GERMANY, FEDERAL REPUBLIC OF	ED	GERMANY	DEU	EUR
GIBRALTAR	LX	GIBRALTAR	GIB	EUR
GREECE (HELLENIC REPUBLIC)	LG	GREECE	GRC	EUR
GREENLAND	BG	GREENLAND	GRL	EUR
ICELAND, REPUBLIC OF	BI	ICELAND	ISL	EUR
IRELAND	EI	IRELAND	IRL	EUR
ITALIAN REPUBLIC	LI	ITALY	ITA	EUR
LUXEMBOURG, GRAND DUCHY OF	EL	LUXEMBOURG	LUX	EUR
MACEDONIA	LW	MACEDONIA	MKD	EUR
MADEIRA ISLANDS (PORTUGAL)	LP	MADEIRA IS	PRT	EUR
MALTA, REPUBLIC OF	LM	MALTA	MLT	EUR
NETHERLANDS	EH	NETHERLANDS	NLD	EUR
NORWAY	EN	NORWAY	NOR	EUR
PORTUGUESE REPUBLIC	LP	PORTUGAL	PRT	EUR
REPUBLIC OF SLOVENIA	LJ	SLOVENIA	SVN	EUR
SANTA MARIA OCEANIC	LP	SANTA MARIA OCEANIC		EUR
SHANWICK OCEANIC	EG	SHANWICK OCEANIC		EUR
SPANISH STATE	LE	SPAIN	ESP	EUR
SWEDEN, KINGDOM OF	ES	SWEDEN	SWE	EUR
SWISS CONFEDERATION	LS	SWITZERLAND	CHE	EUR
U. KINGDOM OF G.B. AND N. IRE.	EG	UNITED KINGDOM	GBR	EUR
YUGOSLAVIA, FED REP OF	LY	YUGOSLAVIA	YUG	EUR

Official Country Name	ICAO	Jeppesen Standard Name	State	Area
ANGUILLA	TQ	ANGUILLA	AIA	LAM
ANTIGUA AND BARBUDA	TA	ANTIGUA	ATG	LAM
ARUBA	TN	ARUBA	ANT	LAM
BARBADOS	TB	BARBADOS	BRB	LAM
BELIZE	MZ	BELIZE	BLZ	LAM
CAICOS ISLANDS	MB	CAICOS IS	TCA	LAM
CAYMAN ISLANDS	MW	CAYMAN IS	CYM	LAM
COSTA RICA, REPUBLIC OF	MR	COSTA RICA	CRI	LAM
CUBA, REPUBLIC OF	MU	CUBA	CUB	LAM
DOMINICA	TD	DOMINICA	DMA	LAM
DOMINICAN REPUBLIC	MD	DOMINICAN REPUBLIC	DOM	LAM
EL SALVADOR, REPUBLIC OF	MS	EL SALVADOR	SLV	LAM
GRENADA	TG	GRENADA	GRD	LAM
GUADELOUPE, DEPARTMENT OF	TF	GUADELOUPE	GLP	LAM
GUATEMALA, REPUBLIC OF	MG	GUATEMALA	GTM	LAM
HAITI, REPUBLIC OF	MT	HAITI	HTI	LAM
HONDURAS, REPUBLIC OF	MH	HONDURAS	HND	LAM
JAMAICA	MK	JAMAICA	JAM	LAM
MARTINIQUE	TF	MARTINIQUE	MTQ	LAM
MEXICO (UNITED MEXICAN STATES)	MM	MEXICO	MEX	LAM

Official Country Name	ICAO	Jeppesen Standard Name	State	Area
MONTserrat	TR	MONTserrat I	MSR	LAM
NETHERLANDS ANTILLES	TN	NETH ANTILLES	ANT	LAM
NICARAGUA, REPUBLIC OF	MN	NICARAGUA	NIC	LAM
PANAMA, REPUBLIC OF	MP	PANAMA	PAN	LAM
PUERTO RICO	TJ	PUERTO RICO	PRI	LAM
SAINT KITTS AND NEVIS	TK	NEVIS I	KNA	LAM
SAINT VINCENT & THE GRENADINES	TV	ST VINCENT	VCT	LAM
SAINT LUCIA	TL	ST LUCIA	LCA	LAM
SAINT KITTS AND NEVIS	TK	ST KITTS	KNA	LAM
SAN ANDRES (COLOMBIA)	SK	SAN ANDRES	COL	LAM
TRINIDAD AND TOBAGO, REP OF	TT	TOBAGO I	TTO	LAM
TRINIDAD AND TOBAGO, REP OF	TT	TRINIDAD	TTO	LAM
TURKS AND CAICOS ISLANDS	MB	TURKS IS	TCA	LAM
VIRGIN ISLANDS OF THE U.S.	TI	VIRGIN IS	VIR	LAM
VIRGIN ISLANDS, BRITISH	TU	BRITISH VIRGIN IS	VGB	LAM

Official Country Name	ICAO	Jeppesen Standard Name	State	Area
AFGHANISTAN	OA	AFGHANISTAN	AFG	MES
BAHRAIN FIR/UIR	OB	BAHRAIN FIR/UIR		MES
BAHRAIN, STATE OF	OB	BAHRAIN	BHR	MES
BANGLADESH	VG	BANGLADESH	BGD	MES
BHUTAN, KINGDOM OF	VQ	BHUTAN	BTN	MES
CYPRUS, REPUBLIC OF	LC	CYPRUS	CYP	MES
INDIA, REPUBLIC OF	VI	INDIA	IND	MES
INDIA, REPUBLIC OF	VE	INDIA	IND	MES
INDIA, REPUBLIC OF	VO	INDIA	IND	MES
INDIA, REPUBLIC OF	VA	INDIA	IND	MES
IRAN, ISLAMIC REPUBLIC OF	OI	IRAN	IRN	MES
IRAQ, REPUBLIC OF	OR	IRAQ	IRQ	MES
ISRAEL, STATE OF	LL	ISRAEL	ISR	MES
JEDDAH FIR	OE	JEDDAH FIR		MES
JERUSALEM	LL	JERUSALEM	ISR	MES
JORDAN, HASHEMITE K/DOM OF	OJ	JORDAN	JOR	MES
KUWAIT, STATE OF	OK	KUWAIT	KWT	MES
LEBANESE REPUBLIC	OL	LEBANON	LBN	MES
MALDIVES	VR	MALDIVES	MDV	MES
NEPAL, KINGDOM OF	VN	NEPAL	NPL	MES
OMAN, SULTANATE OF	OO	OMAN	OMN	MES
PAKISTAN, ISLAMIC REPUBLIC OF	OP	PAKISTAN	PAK	MES
QATAR, STATE OF	OT	QATAR	QAT	MES
REPUBLIC OF YEMEN	OY	YEMEN	YEM	MES
SAUDI ARABIA, KINGDOM OF	OE	SAUDI ARABIA	SAU	MES
SRI LANKA, DEM SOC REP OF	VC	SRI LANKA	LKA	MES
SYRIAN ARAB REPUBLIC	OS	SYRIA	SYR	MES
TURKEY, REPUBLIC OF	LT	TURKEY	TUR	MES
TURKEY, REPUBLIC OF N CYPRUS	LC	TURKEY (REP OF N CYPRUS)	TUR	MES
UNITED ARAB EMIRATES	OM	UNITED ARAB EMIRATES	ARE	MES

Official Country Name	ICAO	Jeppesen Standard Name	State	Area
CAMBODIA, STATE OF	VD	CAMBODIA	KHM	PAC
CAROLINE ISLANDS	PT	CAROLINE IS	PCI	PAC
CHINA, THE REPUBLIC OF	RC	TAIWAN	TWN	PAC
GUAM	PG	GUAM	GUM	PAC

MEMORY CARDS

Official Country Name	ICAO	Jeppesen Standard Name	State	Area
HAWAII	PH	HAWAII	USA	PAC
HONG KONG	VH	HONG KONG	HKG	PAC
JAPAN	RJ	JAPAN	JPN	PAC
JAPAN	RO	JAPAN	JPN	PAC
JOHNSTON ATOLL	PJ	JOHNSTON ATOLL	JTN	PAC
KIRIBATI	PC	KIRIBATI	KIR	PAC
KIRIBATI	PL	KIRIBATI	KIR	PAC
KOREA, REPUBLIC OF	RK	KOREA	KOR	PAC
LAO, PEOPLES DEM REP OF	VL	LAOS	LAO	PAC
MACAU	VM	MACAU	MAC	PAC
MARIANA ISLANDS	PG	MARIANA IS	MNP	PAC
MARSHALL ISLANDS	PK	MARSHALL IS	MHL	PAC
MICRONESIA, FED STATES OF	PT	MICRONESIA	FSM	PAC
MIDWAY ISLANDS	PM	MIDWAY I	MID	PAC
MYANMAR, UNION OF	VY	MYANMAR	MMR	PAC
NORTHERN MARIANA ISLANDS	PG	NORTHERN MARIANA IS	MNP	PAC
OAKLAND OCEANIC CONTROL AREA	P	OAKLAND OCTA	USA	PAC
PALAU, REPUBLIC OF	PT	PALAU	PLW	PAC
PHILIPPINES, REPUBLIC OF THE	RP	PHILIPPINES	PHL	PAC
THAILAND, KINGDOM OF	VT	THAILAND	THA	PAC
VIETNAM, SOCIALIST REP OF	VV	VIETNAM	VNM	PAC
WAKE ISLAND	PW	WAKE I	XJW	PAC

Official Country Name	ICAO	Jeppesen Standard Name	State	Area
ANTARCTICA (ARG, CHILE)	S1	ANTARCTICA (ARG, CHILE)		SAM
ARGENTINA, REPUBLIC OF	SA	ARGENTINA	ARG	SAM
BOLIVIA, REPUBLIC OF	SL	BOLIVIA	BOL	SAM
BRAZIL, FED. REPUBLIC OF	SB	BRAZIL	BRA	SAM
CHILE, REPUBLIC OF	SC	CHILE	CHL	SAM
COLOMBIA, REPUBLIC OF	SK	COLOMBIA	COL	SAM
ECUADOR	SE	ECUADOR	ECU	SAM
FALKLAND ISLANDS	SF	FALKLAND IS	FLK	SAM
FRENCH GUIANA	SO	FRENCH GUIANA	GUF	SAM
GUYANA, REPUBLIC OF	SY	GUYANA	GUY	SAM
PARAGUAY, REPUBLIC OF	SG	PARAGUAY	PRY	SAM
PERU, REPUBLIC OF	SP	PERU	PER	SAM
SURINAME, REPUBLIC OF	SM	SURINAME	SUR	SAM
URUGUAY, REPUBLIC OF	SU	URUGUAY	URY	SAM
VENEZUELA, REPUBLIC OF	SV	VENEZUELA	VEN	SAM

Official Country Name	ICAO	Jeppesen Standard Name	State	Area
ANTARCTICA (AUS, NZ)	A1	ANTARCTICA (AUS, NZ)		SPA
AUSTRALIA	YM	AUSTRALIA	AUS	SPA
AUSTRALIA	YS	AUSTRALIA	AUS	SPA
AUSTRALIA	YP	AUSTRALIA	AUS	SPA
AUSTRALIA	YB	AUSTRALIA	AUS	SPA
BRUNEI DARUSSALAM	WB	BRUNEI	BRN	SPA
COOK ISLANDS	NC	COOK IS	COK	SPA
EASTER ISLAND (CHILE)	SC	EASTER I	CHL	SPA
FIJI	NF	FIJI IS	FJI	SPA
FRENCH PACIFIC OVERSEAS TERR.	NT	FRENCH PACIFIC	PYF	SPA
INDONESIA, REPUBLIC OF	WA	INDONESIA	IDN	SPA

Official Country Name	ICAO	Jeppesen Standard Name	State	Area
INDONESIA, REPUBLIC OF	WR	INDONESIA	IDN	SPA
INDONESIA, REPUBLIC OF	WP	INDONESIA	IDN	SPA
INDONESIA, REPUBLIC OF	WI	INDONESIA	IDN	SPA
KIRIBATI	NG	KIRIBATI	KIR	SPA
MALAYSIA	WM	MALAYSIA	MYS	SPA
MALAYSIA	WB	MALAYSIA	MYS	SPA
NAURU, REPUBLIC OF	AN	NAURU	NRU	SPA
NEW CALEDONIA	NW	NEW CALEDONIA	NCL	SPA
NEW ZEALAND	NZ	NEW ZEALAND	NZL	SPA
NIUE	NI	NIUE	NIU	SPA
PAPUA NEW GUINEA	AY	PAPUA NEW GUINEA	PNG	SPA
SAMOA, AMERICAN	NS	AMERICAN SAMOA	ASM	SPA
SAMOA, INDEP STATE OF WESTERN	NS	WESTERN SAMOA	WSM	SPA
SINGAPORE, REPUBLIC OF	WS	SINGAPORE	SGP	SPA
SOCIETY ISLANDS	NT	SOCIETY IS	PYF	SPA
SOLOMON ISLANDS	AG	SOLOMON IS	SLB	SPA
TONGA, KINGDOM OF	NF	TONGA	TON	SPA
TUAMOTU ISLANDS	NT	TUAMOTU IS	PYF	SPA
TUVALU	NG	TUVALU	TUV	SPA
VANUATU, REPUBLIC OF	NV	VANUATU	VUT	SPA
WALLIS AND FUTUNA ISLANDS	NL	FUTUNA IS	WLF	SPA
WALLIS AND FUTUNA ISLANDS	NL	WALLIS IS	WLF	SPA

Official Country Name	ICAO	Jeppesen Standard Name	State	Area
ALABAMA	K7	ALABAMA	USA	USA
ARIZONA	K2	ARIZONA	USA	USA
ARKANSAS	K4	ARKANSAS	USA	USA
BAHAMAS, COMMONWEALTH OF HE	MY	BAHAMAS	BHS	USA
BERMUDA ISLANDS	TX	BERMUDA	BMU	USA
CALIFORNIA	K2	CALIFORNIA	USA	USA
COLORADO	K2	COLORADO	USA	USA
CONNECTICUT	K6	CONNECTICUT	USA	USA
DELAWARE	K6	DELAWARE	USA	USA
DISTRICT OF COLUMBIA	K6	DISTRICT OF COLUMBIA	USA	USA
FLORIDA	K7	FLORIDA	USA	USA
GEORGIA	K7	GEORGIA	USA	USA
IDAHO	K1	IDAHO	USA	USA
ILLINOIS	K5	ILLINOIS	USA	USA
INDIANA	K5	INDIANA	USA	USA
IOWA	K3	IOWA	USA	USA
KANSAS	K3	KANSAS	USA	USA
KENTUCKY	K5	KENTUCKY	USA	USA
LOUISIANA	K4	LOUISIANA	USA	USA
MAINE	K6	MAINE	USA	USA
MARYLAND	K6	MARYLAND	USA	USA
MASSACHUSETTS	K6	MASSACHUSETTS	USA	USA
MICHIGAN	K5	MICHIGAN	USA	USA
MINNESOTA	K3	MINNESOTA	USA	USA
MISSISSIPPI	K7	MISSISSIPPI	USA	USA
MISSOURI	K3	MISSOURI	USA	USA

MEMORY CARDS

Official Country Name	ICAO	Jeppesen Standard Name	State	Area
MONTANA	K1	MONTANA	USA	USA
NEBRASKA	K3	NEBRASKA	USA	USA
NEVADA	K2	NEVADA	USA	USA
NEW MEXICO	K2	NEW MEXICO	USA	USA
NEW YORK	K6	NEW YORK	USA	USA
NEW HAMPSHIRE	K6	NEW HAMPSHIRE	USA	USA
NEW JERSEY	K6	NEW JERSEY	USA	USA
NORTH CAROLINA	K7	NORTH CAROLINA	USA	USA
NORTH DAKOTA	K3	NORTH DAKOTA	USA	USA
OAKLAND OCEANIC CONTROL AREA	K2	UNITED STATES OF AMERICA	USA	USA
OAKLAND OCEANIC CONTROL AREA	K1	UNITED STATES OF AMERICA	USA	USA
OHIO	K5	OHIO	USA	USA
OKLAHOMA	K4	OKLAHOMA	USA	USA
OREGON	K1	OREGON	USA	USA
PENNSYLVANIA	K6	PENNSYLVANIA	USA	USA
RHODE ISLAND	K6	RHODE ISLAND	USA	USA
SOUTH CAROLINA	K7	SOUTH CAROLINA	USA	USA
SOUTH DAKOTA	K3	SOUTH DAKOTA	USA	USA
TENNESSEE	K7	TENNESSEE	USA	USA
TEXAS	K4	TEXAS	USA	USA
UNITED STATES OF AMERICA	K4	HOUSTON OCEANIC	USA	USA
UNITED STATES OF AMERICA	K6	NEW YORK OCEANIC	USA	USA
UNITED STATES OF AMERICA	K7	MIAMI OCEANIC	USA	USA
UTAH	K2	UTAH	USA	USA
VERMONT	K6	VERMONT	USA	USA
VIRGINIA	K6	VIRGINIA	USA	USA
WASHINGTON	K1	WASHINGTON	USA	USA
WEST VIRGINIA	K6	WEST VIRGINIA	USA	USA
WISCONSIN	K5	WISCONSIN	USA	USA
WYOMING	K1	WYOMING	USA	USA

APPENDIX D HOW DOES GPS WORK?

INTRODUCTION TO GPS

What Is GPS?

Many of the radio-navigation aids used in aviation were originally developed for military use but have now been made freely available to civil users. The Global Positioning System (GPS) has a similar history. The GPS constellation of satellites is an American military facility operated by the US Department of Defence (DoD). This constellation consists of 21 operational satellites plus three spares held in reserve to replace any of the active ones, which might fail. They orbit approximately 10,900 N.M. above the earth in six planes inclined at a 55 degree angle to the Equator and circle the earth twice daily. The orbits are so arranged that a minimum of four satellites will always be visible from any part of the earth's surface at any time. This allows suitable receivers to make extremely accurate determination of latitude, longitude, altitude, velocity and time from satellite signals received by an aircraft, airborne or on the ground.

How Does It Work?

Each satellite carries an extremely accurate atomic clock and continuously transmits precise timing waveforms and data concerning its health status and almanac, orbital information and clock timing corrections. The signals have been designed to be extremely resistant to interference from terrestrial radio transmissions, electronic equipment and weather.

The technique used to establish position using these satellites is one of simple ranging. In other words, position is calculated from measurements of the distances between the observer and a number of satellites. The exact position of each satellite at any given time is known. This information is actually transmitted by each satellite every few minutes. The precise time (in relation to Universal Time) that each satellite starts to transmit its coded signal is also known.

Given this information and the speed of radio waves through space, it is possible to establish the exact distance from each satellite by simple mathematics. For example, if a car leaves point A at exactly 1 o'clock and travels at sixty miles an hour to point B which it reaches at exactly 2 o'clock, we know the distance between points A and B must be sixty miles.

In order to achieve the required degree of accuracy from this technique it would normally be necessary to have an extremely accurate atomic clock built into each receiver as well as each satellite. This would not be viable, as each receiver would then cost tens of thousands of pounds. Instead, an ingenious system is used whereby GPS receivers require to be fitted with only reasonably accurate (and thus low-cost) clocks. This involves two important techniques:

1) Code matching or synchronisation. Each satellite transmits, for civilian use, a unique 1023 bit code. This code is repeated every millisecond (one thousandth of a second).

In the receiver, circuitry generates an identical code that is then slid back and forth in time until it exactly matches the code being received from the satellite.

When a perfect match is achieved, the time at which the receiver is generating the start bit of the code is recorded. The difference in time (or offset) between the receiver generating the code and the satellite generating the code is therefore measurable because the time at which the satellite should have generated the code is known.

HOW DOES GPS WORK?

This gives a very accurate way of measuring the time differences between transmission and reception of the signals generated by the satellites, but does not help with the need for an absolute time reference. One must bear in mind that if the clock in the receiver were only 100 milliseconds (one tenth of a second) out with respect to universal time, the calculated distance from the satellite would have an error of 1,860 miles.

This problem is overcome by a second technique:

2) Making use of an extra satellite. In order to obtain a positional fix in three dimensional space, it is necessary to know the exact distance to each of three satellites. The exact distance is however not known because of the presence of an offset or error in the receiver's clock with respect to universal time.

A fix is nevertheless calculated using the three satellites, all be it erroneous. Once this fix is calculated, a second fix is calculated using satellites 2 and 3 in conjunction with a fourth satellite. This is repeated for satellites 3, 4 and 1 then 4, 1 and 2. This gives four calculated points in space.

If the four calculated points do not overlap, a timing error must be present.

A slight correction is then fed into the receiver's clock and the points are calculated again. They move closer to each other.

This process is repeated until all the calculations tie up correctly at the same point. The exact position in three-dimensional space is then known and the offset in the receiver's clock eliminated.

Similarly, a two-dimensional fix can be established from three satellites.

As a result of this technique the receiver does not initially need to know absolute universal time. All that is needed is a reasonably stable clock for taking relative measurements over the short periods between the signals received from each satellite.

An approximate knowledge of universal time is required, to know which satellite to expect in which part of the sky. The first satellite the receiver acquires after switch on usually gives this.

The exact universal time is transmitted as part of the almanac and health status data by each satellite. This is then corrected by the receiver for signal transition delay as part of the position fix calculations.

Accuracy and Reliability

All GPS satellites transmit two separate pseudo-random codes on two different frequencies.

The most accurate is the P code, which is transmitted at both 1.2276 GHz (1.2276 thousand million cycles per second) and 1.57542 GHz.

The P code is extremely complex and has a repetition rate of one week. This code is restricted to military use only, is capable of supreme accuracy and is supposedly unbreakable.

The signal available to civilian users is transmitted on 1.57542 GHz only and is called the C/A code. C/A stands for Coarse Acquisition.

This code is relatively simple compared to the P code and has a repetition rate of one millisecond.

The present maximum accuracy for receivers using the C/A code is 15 meters.

There is the possibility however of this being intentionally degraded (by feeding random errors into the satellite clocks) to 100 meters for strategic reasons. This is called Selective Availability or S/A and can be implemented at will by the DoD.

Day to day accuracy is monitored by Falcon Air Force Base, Colorado, who receive information from a group of ground stations positioned at Ascension Island, Diego Garcia, Kwagale and Hawaii.

These stations receive the satellite signals and check them for timing accuracy. If any errors are detected, error information is transmitted back to the satellite, which then corrects itself.

Reliability should be good when the full constellation of 24 satellites are in orbit.

Each satellite has three separate clocks on board (one in use and two standby) and in the event of the total failure of a satellite one of the spares already in orbit can be manoeuvred into position within a few hours.

The only time the DoD can predict there may be a substantial break in coverage for civilian users, is at a time of National Emergency, when the whole system may be reverted to P code (military) operation only, for strategic reasons.

Having said this, the system remained fully available to civilian users during the Gulf conflict.

THIS PAGE INTENTIONALLY BLANK

APPENDIX E DIFFERENTIAL FUNCTIONS (Skymap IIIC only)

DIFFERENTIAL GPS

Your Bendix/King unit has been designed to enable it to make use of Differential GPS (DGPS).

What Is DGPS?

GPS on its own is, as we have seen in APPENDIX D , an extremely accurate system for all general navigation purposes. It is not, however, perfect. The most significant source of error in GPS positional calculations is the deliberate downgrading of accuracy known as Selective Availability (SA) described in APPENDIX D . Satellite clocks, although superbly accurate, also have tiny errors, which can affect the accuracy of a fix. So also does any slight drift from a satellite's predicted orbit. The signals from satellites have to pass through the earth's atmosphere and, although radio signals travel at the speed of light, this is only a constant through a vacuum. Things like water vapour in the troposphere and charged particles in the ionosphere do slow down satellite signals and cause slight delays that translate into errors in position. And finally it must be admitted that GPS receivers are not perfect either. These can themselves induce further small positional errors, mainly as a result of receiver noise or clock inaccuracy.

DGPS can virtually cancel out all of the errors due to SA, orbital errors and satellite clock inaccuracy. It also greatly reduces any error caused by the atmospheric delay to radio signals. What DGPS cannot correct for are only the inaccuracies due to the GPS receiver itself and possible "multi-path" errors that (like "ghosting" on a TV) are due to secondary signals being received after reflection off local obstructions. The net result of all this is that while standard GPS can experience errors of between 15 and 100 metres (depending largely on whether SA is active or not) DGPS is already capable of accuracy's down to 1.3 metres horizontally and 2.0 metres vertically.

How Does DGPS Work?

Any two GPS receivers within a few hundred miles of each other will receive satellite signals that have been affected by virtually the same errors as each other. The signals emanate from the same group of satellites, travel through the same portion of the earth's atmosphere and so will be subjected to the same delays. Thus, all the errors (except those due to multi-pathing and to the receivers themselves) will be common to both. So if one of these receivers is located at a fixed point, which has been extremely and precisely surveyed, it can be used as a reference. Instead of using the signals to calculate its position, since it already knows its position it can calculate the errors in the incoming signals.

Having established the magnitude of the errors all that is then needed is an associated transmitter broadcasting signals to tell any mobile GPS receivers in the area exactly what these errors are. The mobile GPS's are then able to use this data to correct for the errors in their raw calculations and to come up with the positional accuracy's mentioned above. DGPS even removes the deliberate degrading of accuracy associated with the DoD's Selective Availability. It is essential to process the data from the reference receiver very rapidly and to transmit the correction data to the mobile GPS receivers almost instantaneously since, especially if SA is active, these errors are constantly varying. Transmitters and receivers have to be designed to work at high baud (bits per second) rates to transfer the necessary data before it becomes out of date.

Uses Of DGPS

Standard GPS provides good accuracy for most navigational tasks, but the additional precision available through DGPS opens up other possibilities in aviation and in many other spheres of activity. Once the aviation authorities are prepared to approve DGPS-based low-visibility approach and landing systems, these could provide low-cost precision facilities worldwide. The benefits of this could be especially useful at small airports where the expense of an ILS or MLS system could never be justified and in developing countries where few if any navigation aids exist today.

DGPS has also already become an essential tool of the offshore oil industry, enabling drill bits to be placed with more precision than any other system. Marine navigation, survey work and cartography, emergency services, agriculture and forestry and road transport fleet management are just some of the non-military applications already relying more and more upon the accuracy of DGPS.

Data Connection

To operate correctly in differential mode, Skymap IIIC requires a 9600 baud RTCM SVC-104 Version 2.0 format sentence.

To connect the Skymap IIIC to a differential receiver unit, connect the 0v or ground lines (pin 5 of the Skymap IIIC connector) and the data output line from the differential receiver to pin 1 of the Skymap IIIC connector.

Once connected to an operating differential receiver, switch your Skymap IIIC on and select Screen 3, GPS Status Screen, by pressing Key 1 from the Main Menu Screen. Once the unit has a fix and differential sentences are being decoded, the word DIFFERENTIAL will be displayed next to the STATE: heading. If the data is not recognised or is not present, the word DIFFERENTIAL will not be displayed.

All the time that DIFFERENTIAL is displayed, the Skymap IIIC is in differential mode and corrections are being applied to the position fix calculations.

APPENDIX F SERIAL DATA OUTPUT SENTENCES

SERIAL DATA FORMATS

The Skymap IIC can output standard aviation RS232 data at 9600 baud or NMEA 0183 format RMC, GGA and RMB sentences at 4800 baud. The data output type is setup on Screen 35 Data Input/Output Setup and Test Screen.

NMEA 0183 Data Format

The serial format is 4800 baud, 8 data bits, 1 stop bit, no parity. Each sentence is followed by a checksum (*hh), carriage return (CR) and a line feed (LF). All three sentences are sent every two seconds.

NMEA – RMC Sentence

\$GPRMC,<1>,<2>,<3>,<4>,<5>,<6>,<7>,<8>,<9>,<10>,<11>*hh<CR><LF>

<1> UTC time of position fix, hhmmss format.

<2> Status, A= Valid position, V=warning

<3> Latitude,ddmm.mmm format.

<4> Latitude hemisphere, N or S.

<5> Longitude, dddmm.mmm format.

<6> Longitude hemisphere, E or W.

<7> Speed over ground (000.0-999.9 knots).

<8> Course over ground (000.0-359.9 true).

<9> Date of fix ddmmyy format.

<10> Magnetic variation 000.0-180.0°.

<11> Variation direction E or W.

Sample sentence.

\$GPRMC,132404,A,5111.465,N,00102.845,W,090.0,304.1,020492,004.3,W*7A

NMEA – GGA Sentence.

\$GPGGA,<1>,<2>,<3>,<4>,<5>,<6>,<7>,<8>,<9>,M,<10>,M,,*hh<CR><LF>

<1> UTC time of position fix, hhmmss.

<2> Latitude, ddmm.mmm format.

<3> Latitude hemisphere, N or S.

<4> Longitude dddmm.mmm format.

<5> Longitude hemisphere, E or W.

<6> GPS quality. 0 = no fix, 1 = fix good, 2 = fix good, differential mode.

<7> Number of sats in use, 00 to 08.

<8> DOP, 01.0 to 99.0.

<9> Antenna height above MSL (metres).

<10> Geoidal offset in metres.

Sample sentence.

\$GPGGA,091636,5119.607,N,00122.001,E,1,04,1.8,18.3,M,-47.0,M,,*5D

NMEA – RMB Sentence

\$GPRMB,<1>,<2>,<3>,<4>,<5>,<6>,<7>,<8>,<9>,<10>,<11>,<12>,<13>*hhCRLF

1. Position valid (A = valid, V = invalid).

2. XX.XX Cross track error in nautical miles.

SERIAL DATA OUTPUT SENTENCES

3. X Direction to steer (L = left, R = right).
4. XXXX Four character start waypoint identifier. (first four characters of name).
5. XXXX Four character destination waypoint identifier.
6. DDMM.MM Destination Lat.
7. X Destination hemisphere (N or S).
8. DDDMM.MM Destination Long.
9. X Destination hemisphere (E or W).
10. XXX.X Range to destination in nautical miles.
11. XXX.X Bearing to destination TRUE.
12. XXX.X closing velocity in knots.
13. X Arrival flag. (A = arrival, V = not arrival).

Sample sentence.

```
$GPRMB,A,00.00,L,1,2,5142.20,N,00217.10,W,048.8,304.0,090.0,V*18
```

Notes on the RMB sentence

The direction in field 3 is direction to steer, i.e. off track to the right, steer left.

If the unit is not in NAV or DIRECT TO mode, the flag in field 1 will show invalid (V).

If the unit is in DIRECT TO mode there will be no start point identifier so field 4 will be blank (spaces). If in DIRECT TO mode where the DIRECT TO point is just a point in space with no name, field 5 will be blank (spaces) also.

The arrival flag in field 13 is set to A when the Waypoint Alert message shows on screen and stays set until the next leg is selected even if the Waypoint Passed message comes up on screen.

At the end of the flight plan or DIRECT TO when the unit drops out of NAV mode, the flag in field 1 will change to a V.

The closing velocity in field 12 is the vectored velocity towards the waypoint. There is no provision for showing negative numbers so if answer is negative, all zeros will be sent.

RS-232C AR-NAV Data Format

The serial format is 9600 baud 8 data bits, 1 stop bit, no parity. A Type 1 sentence is only sent every two seconds. Each line of data is followed by a carriage return (CR) and a line feed (LF) character except the STX and ETX lines.

Header	Data	Description.
STX		Hex 02
Z	aaaaaCRLF	GPS altitude in feet.
A	s dd mmhhCRLF	Latitude where s = N or S, dd = degrees, mm = minutes, hh = hundredths of minutes.
B	s ddd mmhhCRLF	Longitude designated as above.
C	dddCRLF	Magnetic track in whole degrees.
D	sssCRLF	Groundspeed in knots.
E	ddddCRLF	Distance to waypoint in 1/10ths of nm.
G	snnnnCRLF	Cross track error where s = L or R (of track) and nnnn = error in 100ths of an nm.
I	dddCRLF	Desired magnetic track in 10ths of a degree. i.e. BRG to waypoint if you were on track .
K	ccccCRLF	Destination waypoint name. Dashes sent after name if shorter than 5 characters.
L	dddCRLF	Actual magnetic bearing to WPT (in 1/10ths of a degree).
Q	sdddCRLF	Variation. s= E or W. ddd = 1/10ths degrees.
S	---eCRLF	e = NAV flag. - = NAV valid, N = NAV not valid.
T	-----CRLF	Indicates end of sentence type 1.
ETX		Hex 03.

Notes on the AR-NAV sentence.

If the unit is not in NAV mode or does not have a fix, dashes (---) will be sent in fields E, G, I, K, L. Part e of field S will be set to N.

If the unit does not have a fix, dashes will be sent in the latitude, longitude, track and ground speed fields.

If the variation value is greater than 99.9°, a fourth character will be sent in the Q field (i.e. sdddCRLF).

THIS PAGE INTENTIONALLY BLANK

APPENDIX G SERVICE AND WARRANTY

Due to the Company's policy of continual development and routine database updates, new Memory Cards will become available every 28 days. As a registered owner of a Tracker IIC or Skymap IIC, you will be offered a 1/3/6/12 monthly Memory Card subscription.

Keeping your database current is your own responsibility and is extremely important from a safety viewpoint.

To validate your warranty you should fill in and return the enclosed Product Registration Card within 10 days of purchase. Failure to register your unit may result in loss of warranty.

Registering your unit is also essential if you wish to receive an unlock code over the telephone in the event of a PIN lockout. If your unit is not registered, your only option will be to return the unit to a Bendix/King facility. Registering your unit also provides a means of contacting you with information on any new Memory Card upgrade.

If you have a change of address, sell your unit to someone else or if your unit is lost or stolen, please inform us so that we may update our records and keep track of (or help to track down) the unit.

Your unit is warranted to be free from defects in materials or workmanship for a period of two years from date of purchase. The warranty will not cover failures due to abuse, misuse, accident or unauthorised alteration or repair. In the unlikely event of repairs being necessary, please return the complete unit, including antenna, in its carrying case, carriage paid to one of the addresses below.

Skyforce Avionics Ltd

5 The Old Granary
Boxgrove
Chichester
West Sussex
PO18 0ES
United Kingdom
Tel: +44 (0) 1243 783763
Fax +44 (0) 1243 783992

Honeywell Inc

Business & General Aviation
One Technology Center
23500 West 105th Street
Olathe
Kansas
USA
Tel: + 1 913 712 2613
Fax: + 1 913 712 1302

This guarantee does not cover call out or on-site maintenance of the equipment.

If you require further help or advice on installing or operating your unit, please contact in the first instance the dealer from whom you purchased the equipment.

APPENDIX H PREVIOUS SOFTWARE RELEASES

This document has been updated to reflect the features of version 1.22 software. As a general rule, features introduced on earlier versions of software continue to be supported on all subsequent versions, but the introduction of new features and enhancements can mean that screen layouts and some menu items can change from version to version. So the descriptions and illustrations in this guide may not correspond exactly with your system if you are using old software.

For convenience, a summary of the differences between the various versions of operating software is given here. Please note, however, that the software may change with future versions:

Some of the changes described here correct faults that have been found in earlier versions of the software. We strongly advise you to use the latest available software at all times.

Software Version	Release Date	Features
1.00	1 Dec 1998	Initial release.
1.01	4 Dec 1998	<ul style="list-style-type: none"> • Does not invite user to set up display of a data type if there are no examples of that type present in the database • Prevents highlighting of restricted airspace if it is not displayed at current zoom setting • Allows selection of USA airfields with or without a leading K. • Improved icon highlight labelling
1.02	14 Jan 1999	<ul style="list-style-type: none"> • Allow user to select database in DEMO mode • No longer need to re-enter setup variables after updating software • Added descriptive pop-up label when airspace is selected • The destination turning point on the map screen is now

SERVICE AND WARRANTY

Software Version	Release Date	Features
		<p>displayed at all zoom levels in GOTO mode</p> <ul style="list-style-type: none"> • Turning points whose reference is outside the current database are displayed with the default icon on map and view screens • Add AR-NAV type 2 sentence reception • Add ROUTE DISPLAY option in the Nav Set-up, allowing either the active leg or the whole route to be displayed on the map screen • Default CDI scale 5.0nm • “+++” is now displayed after an airport name if there is more than one the same within the database • TRK is displayed as magnetic on the NAV screen • If 3D fix is unavailable, altitude is displayed as “----“ • Allow display of altitude information during log replay • Improves GOTO A RUNWAY feature • External buzzer modulated when AIM sentence selected, else switched • Added two icons to the VRP setup options • Allow icon definitions to be sent by PC link • Improved integrity of route upload over PC link
1.03	9 March 1999	<ul style="list-style-type: none"> • Remove setup options for urban areas, heliroutes, or roads if none present • Allow link to a PC when AIM module fitted • Several minor changes have been made to information and their formats of display (readability issues only) • The pointer position window is now updated after showing the more info screen on an airport • The same name is now used during highlighting and on the map screen where items exist at the same position within the database but have different names

Software Version	Release Date	Features
		<ul style="list-style-type: none"> • Now uses the magnetic variation from the AR-NAV input data when available to ensure consistency with external GPS • Improvements in unit operation when configured to work in Spanish or German • Route Link now clears when waypoint is cleared • Screen is now refreshed after coastline and aeronautical data are displayed when panning • Improved integrity of upload of User Airports over PC link • Waypoint edit screen now allows map to be viewed if waypoints 1 to 100 are all used • Flight log now starts at ≥ 20 knots and stops at < 3 knots to provide greater flexibility for helicopter operations • Fuel calculations using kilometers and statute miles corrected • AIM waypoint alert is cleared at end of route or GOTO
1.04	14 May 1999	<ul style="list-style-type: none"> • More efficient code allows faster panning and zooming • Added Large Aircraft, balloon, and helicopter icons for ownship position • When ground speed falls below the cut-off point for track up and the unit reverts to north up, the aircraft icon is now replaced with the north up style icon • Current leg route line now fixed at magenta, 3 pixels wide. Non active leg lines now fixed at solid white, 3 pixels wide. Track line setting on map setup removed. Extended track line fixed at single dashed white. • On Nav Setup menu, ALL LEGS is now the default for route line setting • Improved logic for highlighting airspace in cases where

SERVICE AND WARRANTY

Software Version	Release Date	Features
		<p>start and end points of arc are in the same quadrant and the arc is >270°</p> <ul style="list-style-type: none"> • Add joystick label saying NAV MODE to the Nav Menu screen • Add Type 2 AR-NAV data output. Improve reception of German AR-NAV type 2. • If set to External GPS and no valid data is available, warning message becomes NO EXTERNAL GPS DATA or EXTERNAL GPS DATA INVALID • NO FIX POSSIBLE banner is not cleared by pointer • Add start-up Jeppesen database expiry message, requiring acknowledgement • TP IMMINENT message changed to WPT ALERT; TP PASSED message changed to WPT PASSED • On all screens where routes are viewed in text format, the letters TP have been removed • All NEAR BCNS keys have been changed to read NEAR NAVAID • The DIRECT ENTRY key has been changed to read TEMP WPT. • Obstructions labels have been changed so that the AGL height is in brackets e.g . 7245 (247) • In all cases the GOTO key has been changed to read DIRECT TO
1.05	(Not Released)	
1.06	(Not Released)	
1.07	29 Nov 1999	<ul style="list-style-type: none"> • If magnetic variation is received from an external GPS, then this is now used throughout the unit when converting between TRUE and MAGNETIC angles • Auto-Zoom feature enhanced. Does not now go below

Software Version	Release Date	Features
		<p>2nm scale</p> <ul style="list-style-type: none"> • Airspace can now be highlighted in the static VIEW AREA and WAYPOINT EDIT screens • When flying a flight plan, pressing the DIRECT TO key on the MAP screen now goes to the ETAs screen. On the ETAs screen, key 2 now reads DATA BASE and takes the user to the DATABASE SELECTION screen • Repositioned Scale bar and destination box on MAP screen • All textual references to “VFR” have been changed to TOPO ON. All references to “IFR” have been changed to TOPO OFF • On AIM Output Test screen, GSI and GS Flag options removed, changed ARRIVAL ALARM to WPT ALERT and MESSAGE ALARM to MESSAGE ALERT • Demo mode map generation speed increased • Improved display of DIRECT TO information when applied over an active flight plan • To/From box now displays airport ICAO code instead of name unless code is unknown • ZOOMING and PANNING messages now displayed during map generation • Engineering PIN number is now required to enter the Screen Positioning screen • Added ability to process external GPS AR-NAV OBS mode data • Improved handling of waypoint display and map redraw • General updates to help text, button text and other text • Now displays ‘+’ after the AIRWAY field if more than one exists with the same name

SERVICE AND WARRANTY

Software Version	Release Date	Features
		<ul style="list-style-type: none"> • A thicker dashed line is used on the visual route flight planning screen • Handles flight logs of less than 2000 points • Date and time now stored and extracted from AR-NAV messages. Time now included in output messages and a date and time stamp is now applied to flight log entries • Default colours have changed, and the pointer line has been changed to CYAN • Changed information box text for the pointer from DIS and BRG to PDIS and PBRG respectively • Reversed operation of heading bug and compass rose on CDI map screen. Heading bug is now displayed as a diamond • Track line length has been increased to 500nm in external OBS mode • WPT PASSED message is no longer displayed continuously in CDI mode • A warning screen is now displayed before the GPS SOURCE can be changed • The default logging rate is now set to zero (off) • AR-NAV binary waypoint longitude decoded • When graphically changing a flight plan and a leg is highlighted, key 2 now reads GRAB LINE. Once this key is pressed, key reverts to ADD WPT • When editing a waypoint manually, keys 1 and 5 swap functionality and key labelled ENTER is changed to SAVE & EXIT • ESCAPE key label changed to SAVE & EXIT on graphical waypoint editing and flight plan screens • All key label and help text references to ROUTE have

Software Version	Release Date	Features
		been changed to FPLN (Flight PLaN)
1.08	(Not Released)	
1.09	(Not Released)	
1.10	10 Feb 2000	<ul style="list-style-type: none"> • All alarms now default to OFF • Automatic timeout of title screen to map screen removed • Auto-leg increment not allowed if in OBS mode • The active flight plan is now the default flight plan selected when accessing the Flight Planning screens • AR-NAV output sends CR instead of CR and LF • Destination text box now displays TEMP WPT if Direct-To or active leg has no name • CDI map screen now displays message HIT JOYSTICK TO VIEW MAP • PANNING and ZOOMING messages are now shown on Flight Planning screens as well as map screens • Various button text changes • NEW WPT button now available on Waypoint Editing screen • The route line is now redrawn if the route changes while the pointer is active • Improved usage of ETAs screen • Disabled the selection of red for all icon features. Default colour for Urban Areas has been changed from <i>Yellow</i> to <i>Light Grey</i> • TO/FROM flag logic improved • Can now select a User Defined airport as a Direct To destination from 10 Nearest Airports screen • Messages 'NO EXTERNAL GPS DATA' and 'INVALID EXTERNAL GPS DATA' now read 'NO EXTERNAL

SERVICE AND WARRANTY

Software Version	Release Date	Features
		POSITION DATA' and 'INVALID EXTERNAL POSITION DATA' respectively
1.11	11 Apr 2000	<ul style="list-style-type: none"> • Changed Title Page
1.12	30 Jun 2000	<ul style="list-style-type: none"> • Waypoint numbers now start from 1 not 0 in AR-NAV output
1.13	10 Jul 2000	<ul style="list-style-type: none"> • Added terrain shading on AMR, ATI and PAI data cards
1.14	17 Nov 2000	<ul style="list-style-type: none"> • Now supports receiving Star5000 AR-NAV data. • Added a Map setup option to allow Airspace Alerting with options OFF (default), 0.5, 1.0, 2.5, 5.0, 10.0 • Improved 'Auto Zoom' operation • Waypoint ETE now rounds up the number of minutes • Sunrise / Sunset page allows cases without sunset (e.g. above 70N in July) • The Position Box on the Map Page now also includes VRPs in its search. Search Distance is 5nm.
1.15	30 Apr 2001	<ul style="list-style-type: none"> • Screen display can swap between TOPO ON and TOPO OFF smoothly • Add GCO airport frequency type • Improved display of terrain and airspace data and highlighting of CTZ. • Aeroplane icon now rotates
1.16	24 May 2001	<ul style="list-style-type: none"> • Modified terrain colours to improve visibility
1.17	31 Jan 2002	<ul style="list-style-type: none"> • Now detects Northstar Protocol Data at 9600 baud • Add new "LOG TRAIL" option on the Map set-up screens. Default 'LOGGING RATE' to 30 seconds. Setting the 'LOGGING RATE' to 'OFF' disables the 'LOG TRAIL' option (i.e. remove option from table) • Enforce consistent display of Airspace Alert messages • Ensure marker waypoint message labels are displayed when an external GPS is in use

Software Version	Release Date	Features
		<ul style="list-style-type: none"> • Suppress extended track line when ground speed is low in North Up mode
1.18	8 Apr 2002	<ul style="list-style-type: none"> • Enables initialisation of new LCD Display (hardware Mod level 2) • The Screen Alignment page now allows the joystick to move the screen up and down instead of focus. The help text has changed to reflect this.
1.19	31 July 2002	<ul style="list-style-type: none"> • Enable display of AND cartographic data • Re-instated screen focus on joystick up and down on Screen Alignment page
1.20	27 Apr 2004	<ul style="list-style-type: none"> • Enable displaying of ARINC 424-15++ airspace data, with airspace labelled by class • Enables use of a new 12-channel internal GPS (hardware Mod 5) • The Extended track line has been made thicker, to help visibility in bright sunlight • The current leg track line has been given a black outline so it does not become confused with controlled airspace • In CDI mode the next Course Box now displays next leg • Engineering Log Page changed to allow mods to be identified individually
1.21	22 Jul 2004	<ul style="list-style-type: none"> • Prevent display of spurious lines at the join between large inland water features • N^ (North up) icon always shown when map is displayed North-Up • Made entry of negative TAT in the WIND/TAS page more intuitive • Logs can be played back at higher simulated speed than actual aircraft
1.22	18 Feb 2005	<ul style="list-style-type: none"> • MSA displayed correctly on Nav Menu and Flight

SERVICE AND WARRANTY

Software Version	Release Date	Features
		<p>Planning pages for locations West of 0° and South of Equator. (ref: Skyforce Service Letter TR/SKY/072)</p> <ul style="list-style-type: none">• Obstacle label no longer displayed with obstacle name in More Info box

ALPHABETICAL INDEX

Abbreviations	3	En-route ETA's	40
AC Power	16	EPROM	14
Acronyms	3	Extended Track	3
ADVISORY ALT	53	Flight Plan	34
Airport Information	28	Flight Plans	18
AIRSPACE ALERT	4	FPLN OFF	19
Airways Flight Planning	25	FPM	52
ALARM OFF	42	Fuel Planning	53
almanac	5	fuse	16
alphabetic	3	Garmin	11
alphanumeric	3	Global Positioning System	1
AMR	1	GPS	1
Antenna	18	GPS ALTITUDE	1
AR-NAV	3	GPS Receiver	15
Arrival	43	ground speed	4
Arrival Alarm	42	GS	28
ATI	1	Help	1
Auto Declutter	3	ICAO	1, 3
AUTO LEG SELECT	8	Icon Information	30
AUTO LOCK	11	icons	14
AUTO NEXT LEG	42, 8	Initialisation	2
Auto Power-On Lock	11	Inserting a Waypoint	20
AUTO ZOOM	3	Installation	13
barometric altitude	3	INVALID EXTERNAL POSITION DATA26	
Battery	1	Jeppesen	1
baud	3	landscape	2
Beacon Information	29	local offset	9
bearing to user waypoint	3	LOCAL OFFSET	6
care	2	Lock Out	2
CDI	44	Logs	14
cigarette lighter	16	LORAN	11
CLIMB	53	LRG TXT	32
Coarse Acquisition	2	MAP	26
Course Deviation Indicator	7	Memory Battery	1
cross track error	3	memory cards	1
cursor field	3	minimum safe altitude	4
database	22	MORA	2
Definitions	3	NAV MENU	32
Demo Mode	47	NEAR APTS	37
Density Altitude/	49	NEAR NAVAID	37
DESCEND IN	52	New Data Card	3
DGPS	1	NMEA	1
Diagnostic	13	NO EXTERNAL POSITION DATA.....26	
Differential	1	NO FIX POSSIBLE	26
Dilution of Precision	6	Northstar	11
Direct To	20	Note Pad	3
DOP	6	NVM	14
E6-B Calculator	49	operating system	11
Engineering Log	14	ORIENTATION	2

ALPHABETICAL INDEX

P code	2	Status	5
PAI	1	Sunrise	54
PANNING	28	Sunset	54
PETE	28	TAS	49
PIN	9	Ten Nearest	36
PIN Lock	2	terminal user waypoints	4
portrait	2	TOPO OFF	32
Portrait	11	TOPO ON	32
position reference	26	Tracker	11
Pseudo CDI	44	Trimble	11
RAIM	4	Turn Anticipation	42
RAM	14	TURN ANTICIPATION	8
RAM Lost	1	unlock	1
REF	19	User Defined Airports	14
RESET STICK	28	User Waypoints	13
RS232	1	UTC	7
satellites	1	Vertical Navigation	51
Screen Orientation	11	VNAV	51
Selective Availability	3	warranty	1
Self Test	2	waypoint	24
Setup	1	Winds Aloft	49
short cuts,	14	WPT ALERT	42
Soft Keying	11	WPT PASSED	42
Standard	11	ZOOM IN,	28
START DESCENT	53	ZOOM OUT	28